

SYM	改訂日 DATE	改訂内容 DESCRIPTION	ページ PAGE	担当 DESIGNED
	2025.09.24	新規図面登録	-	N. Uemura

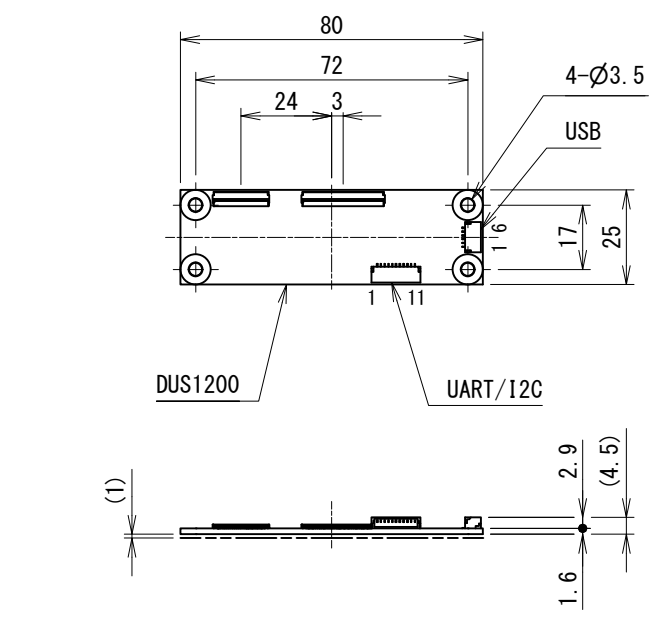
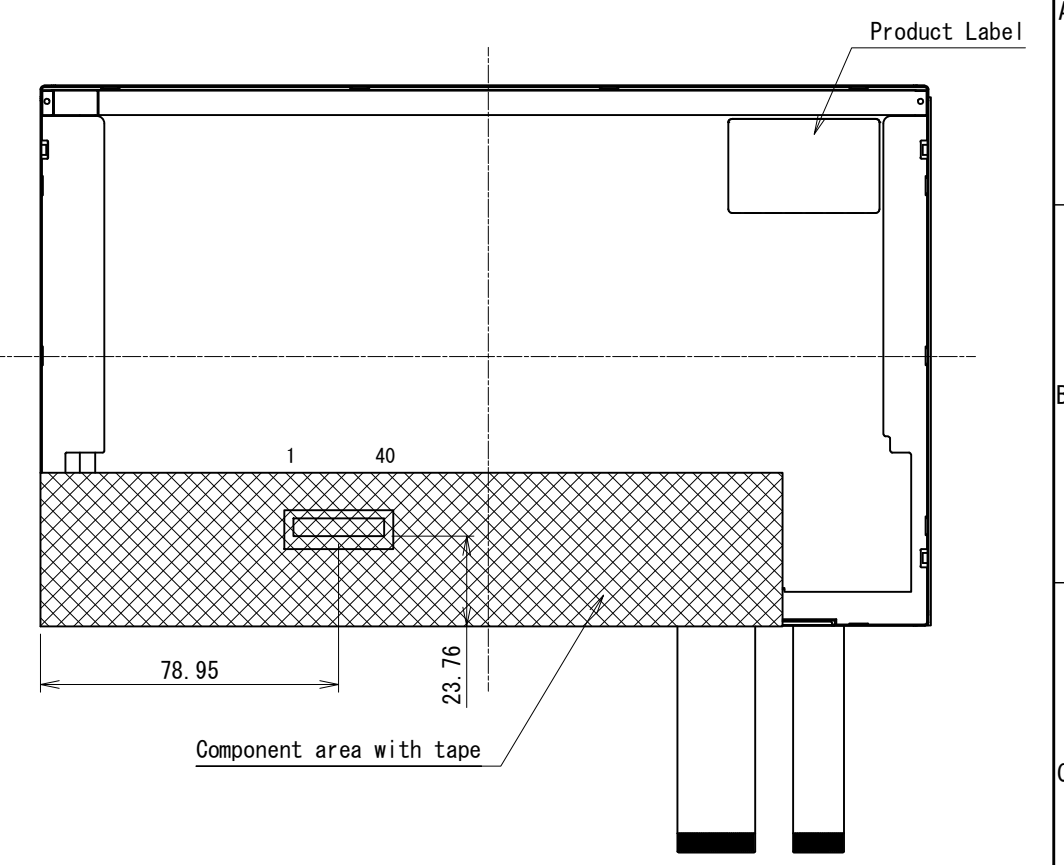
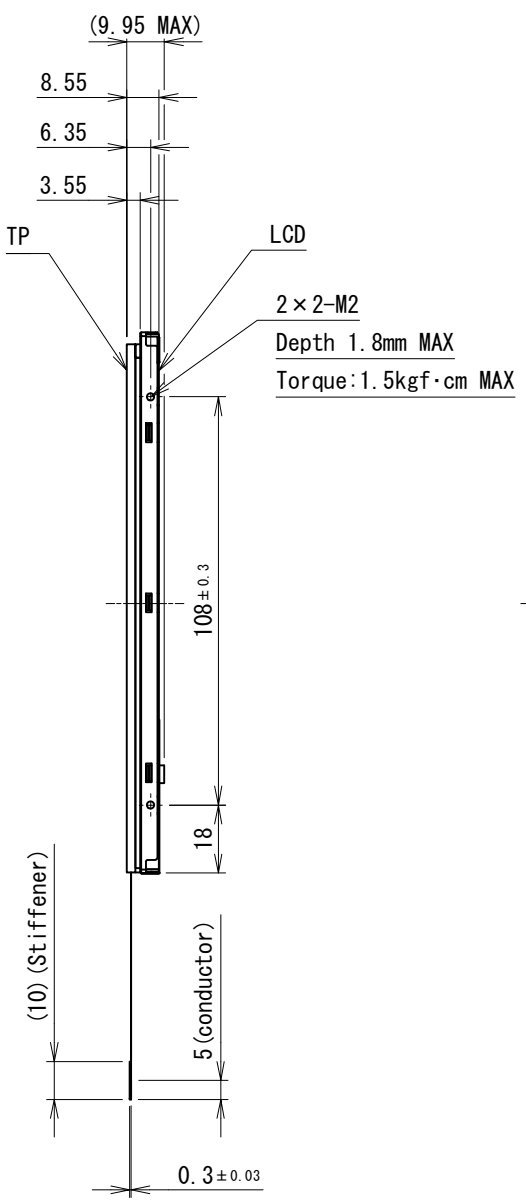
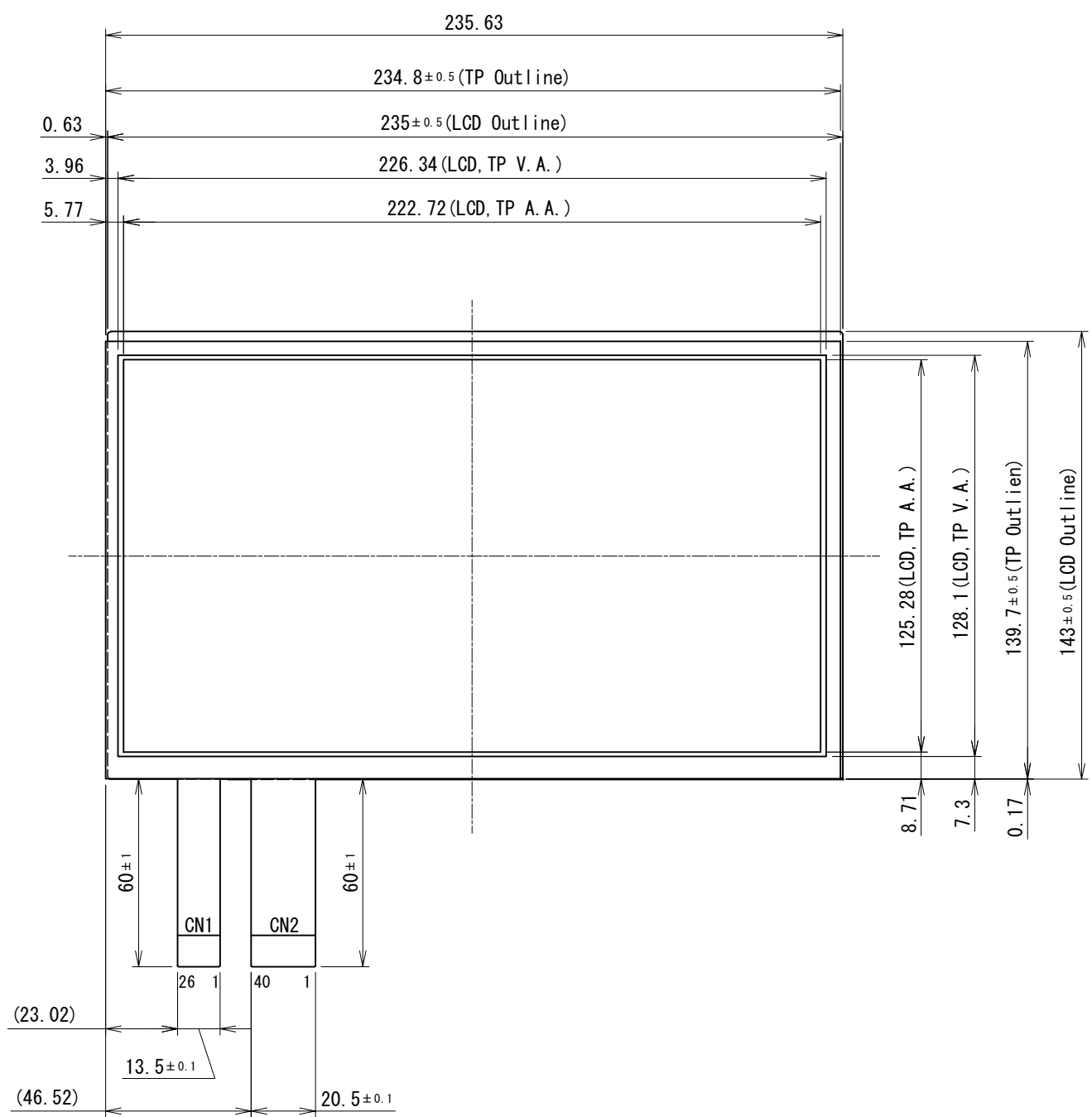

- NOTES
1. タッチ方式：投影型静電容量方式
Type: Projected Capacitive Touchscreen
 2. ITOガラス：厚さ2.35mm
ITO Glass: thickness 2.35mm
 3. 指示無き寸法公差は、±0.5mmとする。
Tolerance shall be of ±0.5mm Unless specified otherwise.

製図日 ISSUED	2025.9.24	部署 SECTION	Technical Dept.	尺度 SCALE	CAD登録名 CAD FILE NAME	OUTLINE_TK-SPA101WS-101	RoHS対応品 RoHS compliant
承認 APPROVED		検図 CHECKED		1:2	製品名 MODEL	TK-SPA101WS-101	
		製図 DRAWN		単位 UNIT	図名 TITLE	OUTLINE	ページ PAGE
T. Okada	S. Yoshimoto	N. Uemura	S. Takada	mm			1 / 1
DMC Co., Ltd.			A3	図番 DWG No.	SM3-002573-10		