

SYM	改訂日 DATE	改訂内容 DESCRIPTION	ページ PAGE	担当 DESIGNED
	2025. 11. 20	新規図面登録	-	N. Uemura

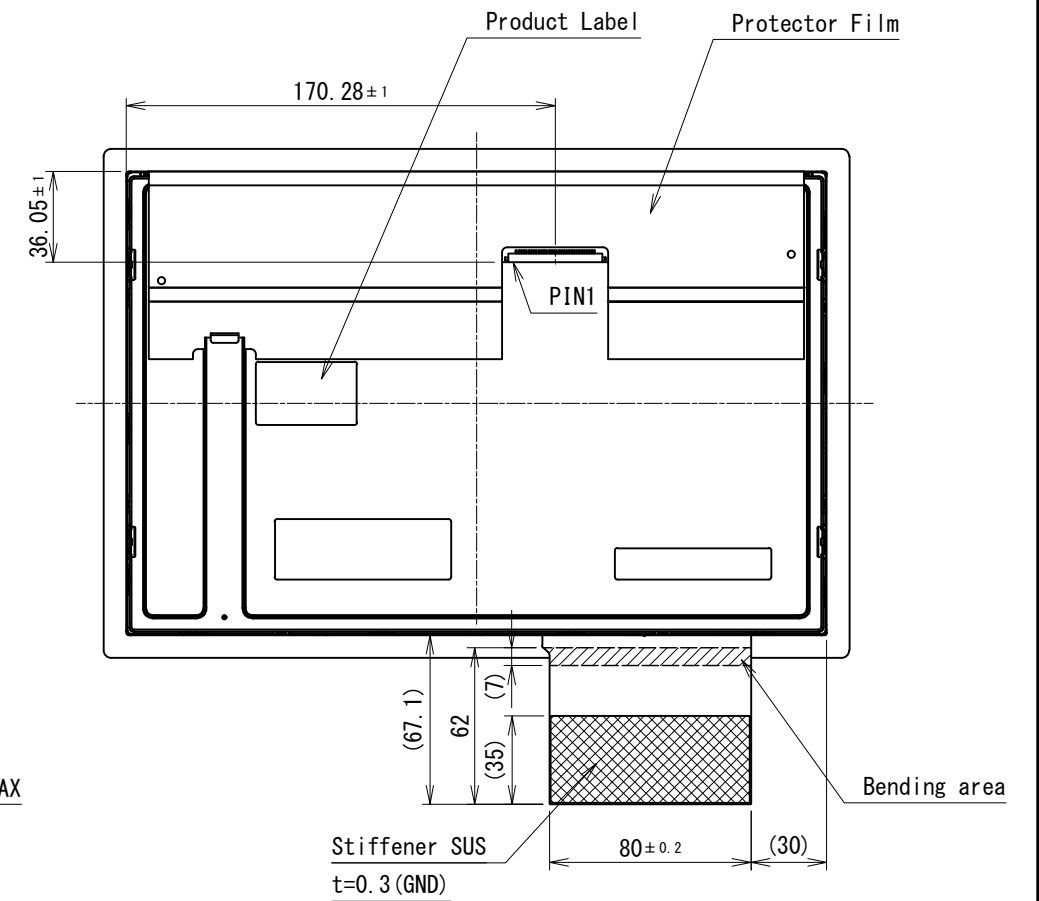
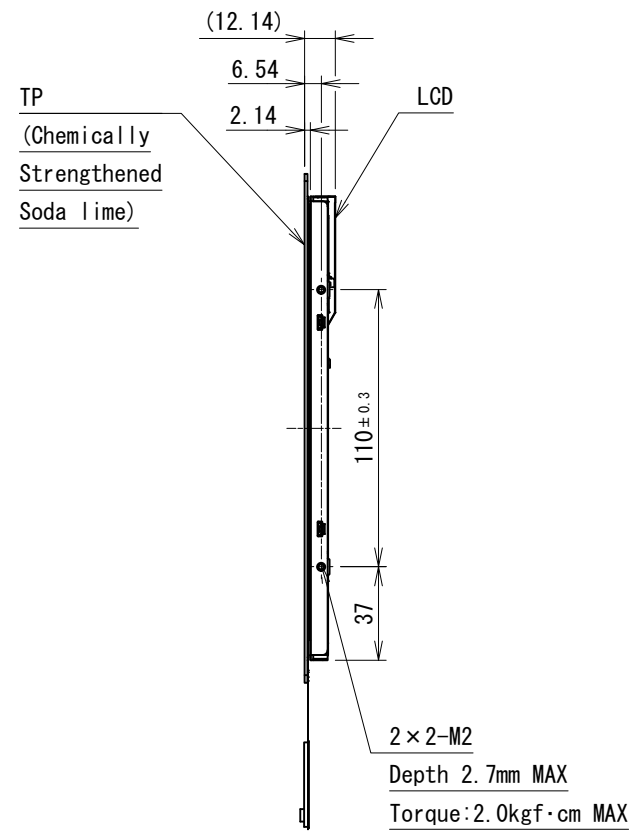
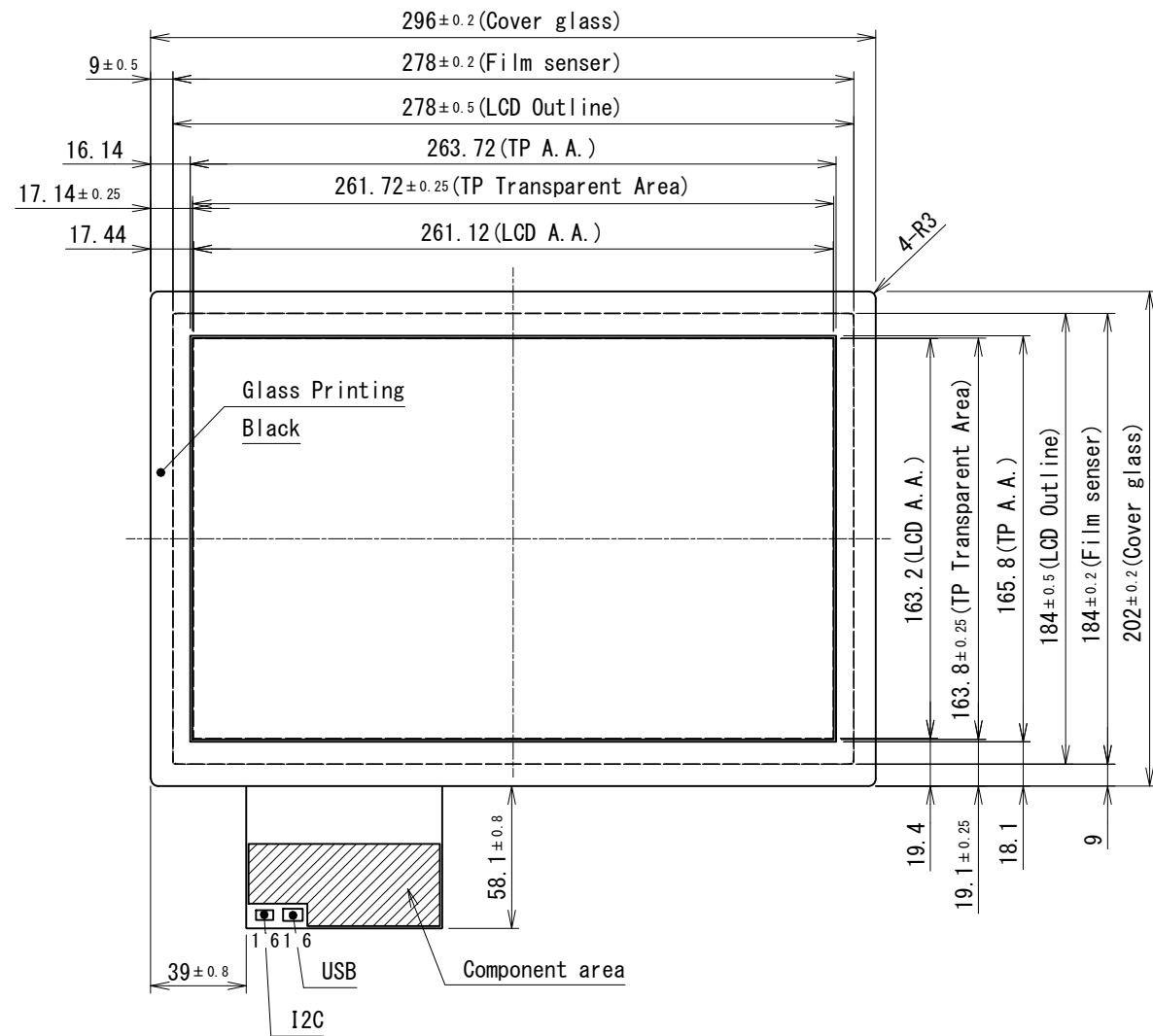

- NOTES
- タッチ方式：投影型静電容量方式
Type: Projected Capacitive Touchscreen
 - カバーガラス：厚さ1.1mm
Cover Glass: thickness 1.1mm
 - 指示無き寸法公差は、±0.5mmとする。
Tolerance shall be of ±0.5mm Unless specified otherwise.

製図日 ISSUED	2025. 11. 20	部署 SECTION	Technical Dept.	尺度 SCALE	CAD登録名 CAD FILE NAME	OUTLINE_TK-SPA121WX-111	RoHS対応品 RoHS compliant
承認 APPROVED		検図 CHECKED		1:3	製品名 MODEL	TK-SPA121WX-111	
		製図 DRAWN		単位 UNIT	図名 TITLE	OUTLINE	ページ PAGE
T. Okada	S. Yoshimoto	N. Uemura	N. Uemura	mm			1 / 1
DMC Co., Ltd.			A3	図番 DWG No.	SM3-002622-10		