

SYM	改訂日 DATE	改訂内容 DESCRIPTION	ページ PAGE	担当 DESIGNED
	2025.10.28	新規図面登録	-	N. Uemura

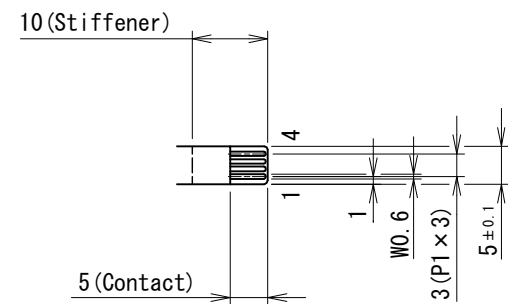

PIN OUT	
1	YD
2	XL
3	YU
4	XR

Detail A

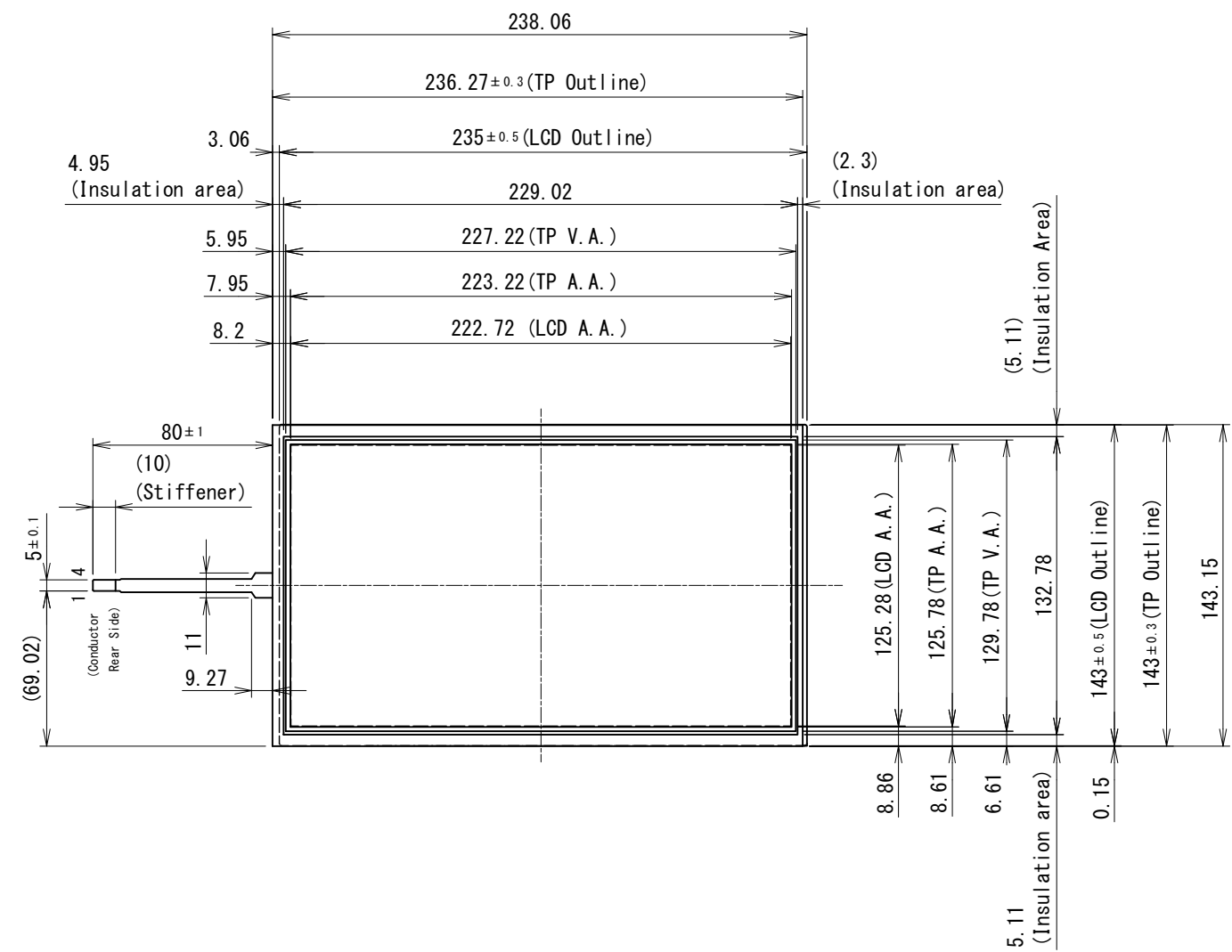
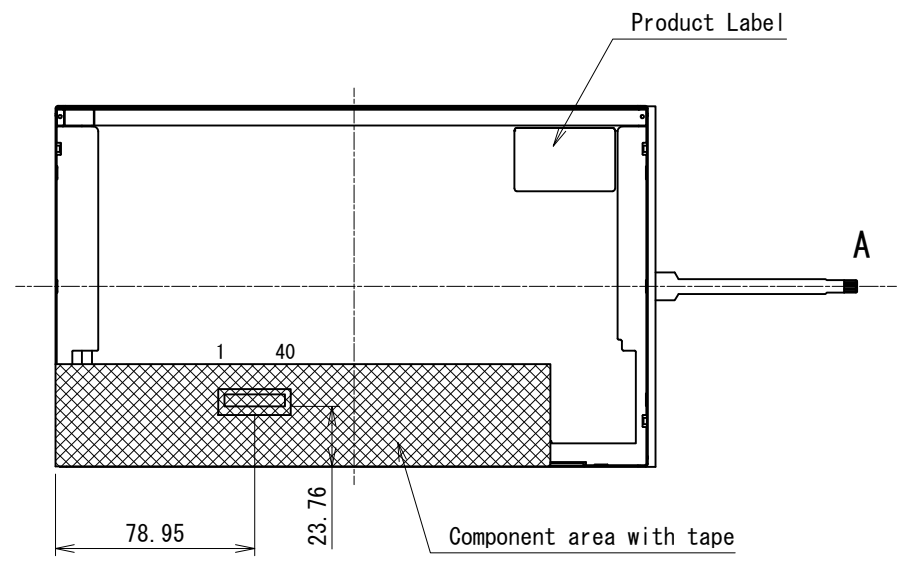
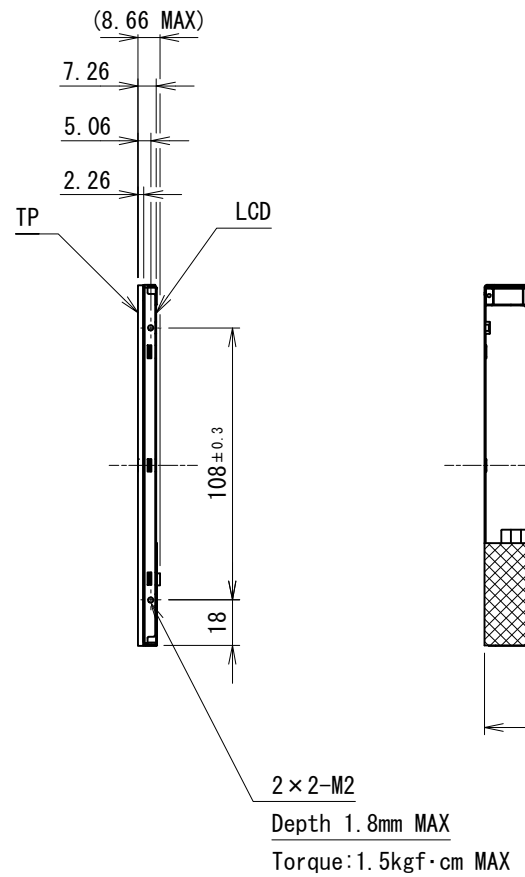

- NOTES
- タッチ方式：抵抗膜方式  
Type: Resistive Touchscreen
  - ITOガラス：厚さ1.8mm  
ITO Glass: thickness 1.8mm
  - 指示無き寸法公差は、±0.5mmとする。  
Tolerance shall be of ±0.5mm Unless specified otherwise.

製図日 ISSUED	2025, 10, 28	部署 SECTION	Technical Dept.	尺度 SCALE	CAD登録名 CAD FILE NAME	OUTLINE_TK-SRA101WS-101	RoHS対応品 RoHS compliant
承認 APPROVED		検図 CHECKED		1:3	製品名 MODEL	TK-SRA101WS-101	
		製図 DRAWN		単位 UNIT	図名 TITLE	OUTLINE	ページ PAGE
T. Okada	S. Yoshimoto	S. Takada	N. Uemura	mm			1 / 1
DMC Co., Ltd.			A3	図番 DWG No.	SM3-002584-10		