 TM Series
15.6" Wide
LCD Touchscreen Monitor
Model "G"
Model "H"

Instruction Manual

Model: TMG-156FH01-01
TMH-156FH01-01

DMC Co. Ltd.
<https://www.dush.co.jp/english/>

Introduction

Thank you for purchasing DMC's products.

This manual describes the functions of the TM series.

Please read this manual carefully and use the product properly.

The product will be referred to as "TM" hereinafter.

Please note, specifications described in this manual are subject to change without prior notice.

Copyrights and Trademarks

- The copyright of this instruction manual is rightfully owned by DMC Co., Ltd.
- Reproduction and/or duplication of the product and/or this manual, in any form is strictly prohibited.
- Contents of this product and/or this manual are subject to change without prior notice.
- Although all efforts have been made to ensure the accuracy of this product and/or the contents in this manual, should you notice any errors or have any questions, please contact and notify us.
- We will not be held liable in any way for damages or losses, nor be held responsible for any claims by a third party as a result of using this product.
- Other product and company names mentioned herein are trademarks or registered trademarks of their respective owners.





Safety Precautions

Please go through and follow the below precautions before use.

Safety Symbols

Safety symbols are noted throughout this manual to ensure the proper use of the TM.

The indications and meaning of the symbols are as follows.

 Warning	Indicates a procedure, condition, or statement which, if not strictly observed, could result in severe personal injuries or death.
 Caution	Indicates a procedure, condition, or statement which, if not strictly observed, could result in severe personal injuries or property damage.
	Indicates a procedure, condition, or statement that must not be done for correct use of the product. (Prohibited)
	Indicates a procedure, condition, or statement that should be strictly followed for correct use of the product. (Mandatory)

Warnings

Warnings for Design

- ⊘ Designing switches that might cause human injuries and/or property damage on the touchscreen is strictly prohibited. Unintended output signals due to malfunction of the main unit and/or cables can lead to serious injuries. Design the system so that switches that perform critical operations are equipped on devices other than the TM itself.
- ⊘ Designing safety related switches on the TM is prohibited. Switches related to safety, such as emergency stop switches, should be installed on a different hardware.
- ⊘ Do not use this product as a critical warning device that may cause injuries, serious property damage, or production stoppage. Critical warning indications and alert-related controls should be structured on an independent and redundant hardware or mechanical interlocks.
- ⊘ The TM is not intended for use in applications that require extremely high reliability and safety such as aircraft equipment, aerospace equipment, trunk line communication equipment, nuclear power control equipment, and life sustaining medical equipment. It is not intended for use in these applications.
- ❗ When using the TM for purposes that concerns high reliability and safety in terms of functions and accuracy such as transport equipment (trains, automobiles, ship, etc.), disaster prevention and security equipment, various safety devices, medical equipment that does not concern life sustaining, be sure to have safety features including redundancy and malfunction prevention measures into the entire system which it will be incorporated.
- ⊘ Display will black out when the backlight goes out. If mistakenly operated in this condition, it might result in improper operation. Do not design touch-switches that might cause human injuries and material damages due to improper operation on the TM.

Warnings for Handling

- ⊘ Do not modify or disassemble the TM. Doing so may cause fire and /or electric shock.
- ⊘ Do not use around flammable gas. It may cause explosions.
- ⊘ Do not allow any kind of liquid, such as water, and metals to get inside of the product. It may cause fire and/or electric shock.
- ⊘ In any abnormality such as smoke, unusual odor, or unusual noise is detected, disconnect the power plug, and discontinue use. If use is continued, it may cause fire or electric shock.

Warnings for Wiring

- ❗ For proper wiring and installation, please refer to the instruction manual and specifications. Failure to do so may cause fires and/or electric shocks.
- ❗ Before installing the power cable, make sure power is not being supplied from the power source. Failure to do so may cause electrical shocks.
- ⊘ Do not use power voltage other than what is specified. Failure to do so may cause fires and/or electric shocks.

Cautions

Cautions for Disposal

- ❗ When disposing the product, please treat it as industrial waste.

Precautions for Safe Use

- ⊘ Do not press the display with strong pressure or hard objects. It may break the display and cause injuries.
- ❗ Please use this product within the specified ambient temperature and humidity range. If not used properly within the specified range, it may cause malfunctions.
- ⊘ Do not press down on the display area with sharp objects such as mechanical pencils or screw drivers. It may damage the display.
- ❗ If the surface of the TM gets dirty, wipe with a dry, soft cloth damped in a neutral detergent then wrung out tightly. Do not use thinner or organic solvents.
- ⊘ Avoid using the TM in areas where rapid temperature change that can cause condensation. It may cause malfunctions.
- ⊘ In order to prevent product temperature from rising, avoid using in areas where heat can build up. Also avoid storing or using in areas of high temperature.
- ⊘ Avoid storing or using the product in direct sunlight, dusty areas, or in areas where it can be exposed to oil fumes and/or water vapor.
- ⊘ Do not use or store all precision equipment including the TM in areas where it is subject to shock or vibration.
- ⊘ Avoid using or storing in areas where gasified chemicals are diverged into the air or where chemical adhering to the product can occur.
- ❗ When using power source with slow rise-time and fall-time, it may not operate properly. When turning the power back on after switching off the product, be sure to drop the voltage to 0 before switching it on.

Handling of LCDs

- 1) The LCD display contains skin-irritating materials. If liquid materials flow out due to damage and comes in contact with skin, wash the area under water for more than 15 minutes. If it gets in the eyes, wash your eyes immediately under running water and consult a doctor.
- 2) Please note that The LCD display may show uneven brightness depending on the contents being displayed. This is not a malfunction.
- 3) Then LCD display may have minute spots (black or bright). This is a basic characteristic of the LCD display and not a malfunction
- 4) When the LCD display is viewed outside the specified view angel, the display color might seem to change. Please note this is a basic characteristic of the LCD display and not a malfunction.
- 5) When displaying a same image for a long period of time, it may cause afterimages. Please note that this is a basic characteristic of the LCD and not a malfunction.
In order to avoid afterimages, change the display image periodically and avoid displaying the same image for a long period of time.

Handling of Projected Capacitive Touchscreens (TMG)

- 1) Changes in the surrounding environment and/or elements that change the electric field, such as capacitors with large capacitance, power supply units, metals, and other materials with high dielectric constants are near, it may affect the coordinate detection. Keep as much distance as possible from those unstable elements mentioned above when designing.
- 2) Connect the FG (Frame GND) of the TM main unit to FG (Field GND). Touchscreen operation may become unstable.
- 3) Touchscreen operation may become unstable depending on the installation environment due to the characteristic of the touchscreen. For correct use, please perform calibration of the sensor sensitivity of the touchscreen when installing the equipment. For details, please refer to "[4.4 Calibration](#)".
- 4) Although the touchscreen is covered with tempered glass, please be careful when handling as it may break when struck by hard objects.
- 5) The touchscreen may cause malfunction if there are drops of water on the surface of the touchscreen. Please wipe it dry before use.
- 6) Due to the characteristics of the touchscreen, touching slightly outside the display area may be detected as the coordinates of the edge of the touchscreen. Please take this into consideration when designing applications.

Handling of Analog Resistive Touchscreens (TMH)

- 1) Applications that require a point on the touchscreen to be pressed for a long time may cause failures due to its structural features. Please be careful.
- 2) The touchscreen is made of surface film and tempered glass. There is a possibility of the touchscreen becoming inoperable due to cracks and/or other damages to the surface film. Also, the tempered glass can easily damage if scratched. Please handle the touchscreen so it does not come in contact with hard objects.
- 3) Due to the characteristics of the touchscreen, touching slightly outside the display area may be detected as the coordinates of the edge of the touchscreen. Please take this into consideration when designing applications.
- 4) The coordinates of the touchscreen may shift over time or depending on the environment of use.
If the coordinates shift, please perform calibration (coordinate correction). For details, please refer to "[4.4 Calibration](#)".
- 5) Due to the structure of the touchscreen, sealing material may be visible at the edge (upper right corner when viewed from the front) of the touchscreen.
Please refer to the Shipping Standards for details. (Please contact our sales representatives.)

Table of Contents

1. Features	1
1.1 Features.....	2
1.2 Line-Up	3
2. Product Configuration	4
2.1 Names and Functions of Each Parts	5
2.2 Options.....	6
2.3 Installing the TM	8
2.4 Wiring.....	10
3. OSD.....	14
3.1 OSD Menu (Factory Default Setting).....	15
4. Touch Screen Properties	16
4.1 System Requirements	17
4.2 Installation.....	18
4.3 Setting.....	22
4.4 Calibration.....	27
5. Maintenance.....	30
5.1 Maintenance	31
6. Troubleshooting	32
6.1 Display	33
6.2 Touchscreens.....	34
7. Others.....	35
7.1 Warranty and Repair.....	36
7.2 Production Discontinuance	37
7.3 Inquiries	38

1. Features

Chapter Contents

1.1	Features	2
1.2	Line-Up	3

1.1 Features

- Front surface a full flat design.
- Slim type chassis.
- Supports HDMI video signal as a series.
- USB3.0 Upstream Port with shock-resistant “Standard Type B” connector.
- A lineup of projected capacitive touchscreens: TMG Series
 - Supports five-point touch
- A lineup of light weight resistive touchscreen: TMH Series
 - Resistive type that supports gestures such as flick, pinch in/out, rotate)
- Can be operated with gloves.
 - *Some glove may not be compatible depending on the type and the environment in which they are used.
- Supports DC Power input (12V).
 - The connector uses DC jack with a screw when used with a compatible DC plug, it will prevent disconnection.
 - AC adaptor with screw-lock is available as option.
 - It can also be used with a regular DC plug (without a screw-lock).
- Long-life, high-luminance LCD for industrial equipment.
- The IPS type LCD provides a wide view angle and can be displayed as either portrait or landscape mode.
- Mounting angle of the VESA Box can be changed (variable angle: 90degrees) /
Improved routing flexibility of the interface cable.
- Adoption of VESA mounting standard (100 x 100mm).
- Stand-alone made possible by using an optional free-stand.

1.2 Line-Up

Model	Specification			
	LCD size	Touchscreen type	Video Input	USB (Host I/F)
TMG-156FH01-01	15.6 inch wide	Projected capacitive	HDMI	USB3.0 Type-B (USB2.0 Type-B connectable)
TMH-156FH01-01	15.6 inch wide	Analog resistive※	HDMI	USB3.0 Type-B (USB2.0 Type-B connectable)

※ Analog resistive touchscreen used in TM supports gesture operations such as flick, pinch in, pinch out, and rotate. (Does not support two-point touch.)

2. Product Configuration

Chapter Contents

2.1	Names and Functions of Each Parts	5
2.2	Options	6
2.3	Installing the TM	8
2.4	Wiring	10

2.1 Names and Functions of Each Parts

TMG-156FH01-01, TMH-156FH01-01

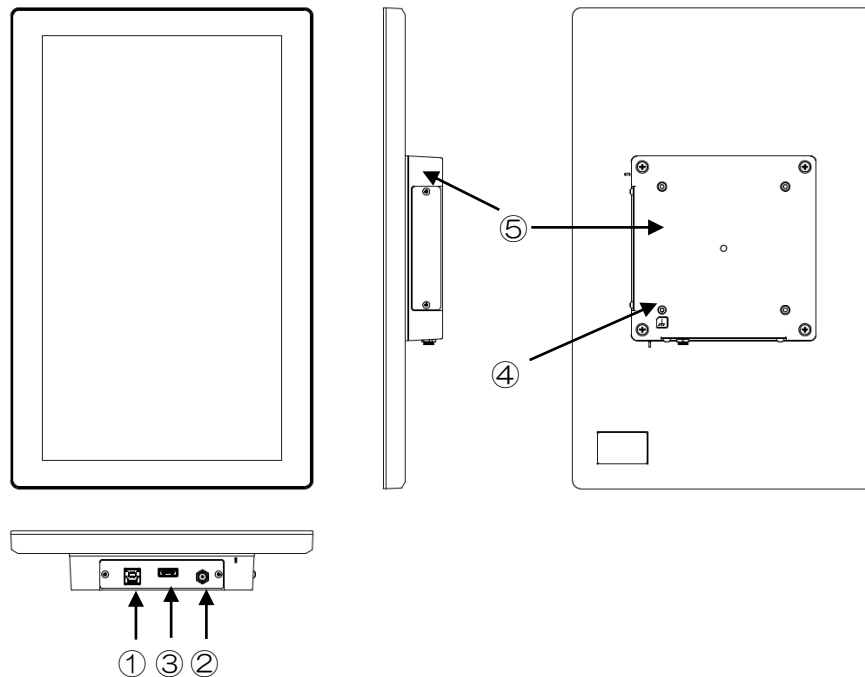

Part No	Name	Function
①	USB Host I/F*1	USB3.0 Standard Type-B Connector (USB2.0 Type-B connectable)
②	Power Input	Input power. (12VDC)
③	Image Input (Digital)	HDMI connector
④	FG Terminal	Connects to Field GND.
⑤	VESA Box	Can be rotated by customer

*1 Connect an USB cable when using as a touchscreen monitor.

2.2 Options

“AC adaptor”, “Self-standing stand” are available as option.

2.2.1 AC Adaptor

Model: ATS065T-P120B15210 (customized model)

Manufacturer: Toki Trading Ltd.

• AC Adaptor 1 unit

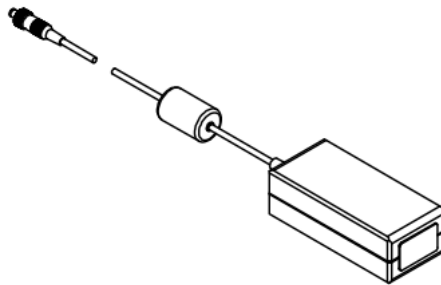

• AC cord 1pc

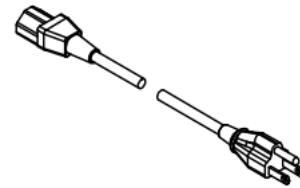

<Note>

Warranty coverage: Coverage within the AC adaptor manufacturer's warranty.

Make sure the power cord provided conforms to the standards specified for the country or region in which it will be used.

2.2.2 Self-Standing Stand

Model: SWST-01-001

2.2.2.1. Items included

- Stand (arm) 1unit



1pc screw for assembly included.

- Stand (base) 1 unit



- VESA mounting screw 4pcs

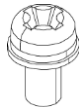

- List of included items 1copy



2.2.2.2. Assembly Instruction

- 1) Remove the screw attached to the arm.
- 2) Put together the arm and the base.
- 3) Screw together with the screw removed at 1).

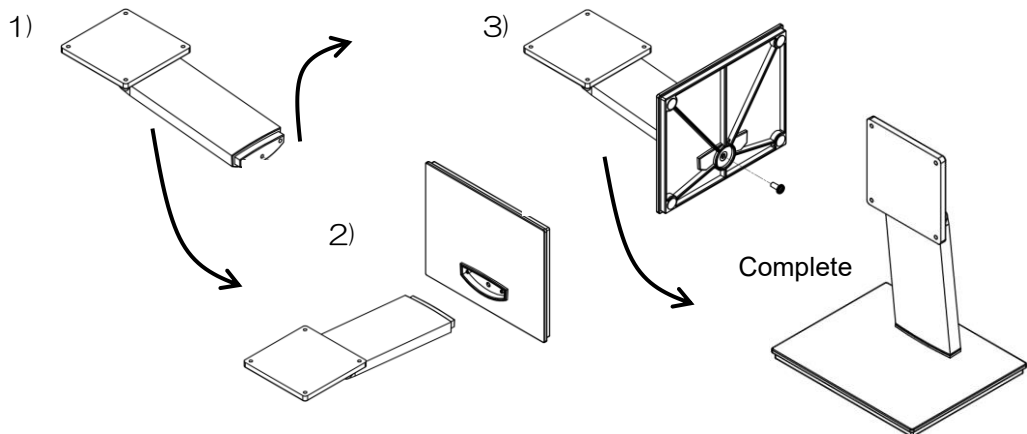

2.3 Installing the TM

2.3.1 Installing Conditions (Precautions)

- To install the TM, use the M4 screw holes (VESA Standard 100mmx 100mm) provided in the VESA box.
- When installing using a commercially available arm or stand, be sure to select one that can withstand the weight of the TM.
- Please be careful not to drop the product as it may cause human injury or damage to the product.
- Make sure there is enough room for inserting and removing of cables when installing.
- Use the product within the specified ambient operating temperature and humidity.
- Please install so the touchscreen does not come in contact with metal.
- If metal should come near the touchscreen, be sure to leave a space of 2mm or more between the touchscreen and metal, otherwise it may cause malfunctions.

2.3.2 Installing of Optional Stand

Use the M4 screws provided with the optional stand for installation.

Tightening torque is 0.7 to 0.8N-m.

Angle adjustment range is +90° to -5°.

If installed to our option stand “SWST-01-001”, the angle can be adjusted for easy viewing.

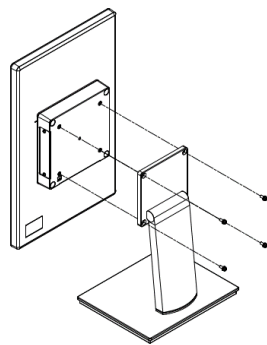

Installation

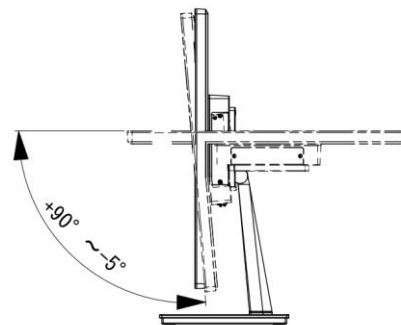

Stand adjustment range

SWST-01-001 Installation Diagram

2.3.3 Installing “VESA Standard” Arm

The TM can be installed to a commercially available arm and/or stand.
 Parts to be used for installation shall meet the UL1678 standards.
 Please refer to the manual of the arm for installation procedures.
 Installing hole dimensions are as follows (VESA Standard 100mm x 100mm)

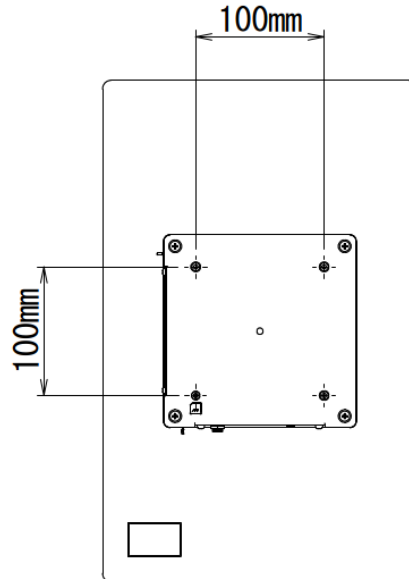

Use M4 screws with tightening torque of 0.7 to 0.8N-m
 Please select the M4 screws so the penetration depth of the screw is 8mm or less from the backside.

VESA Standard

VESA is the abbreviation for “Video Electronics Standards Association”, an industry organization that establishes standards for computer displays.

VESA established SVGA standards and VL bus standards and standardized below 2 types of LCD monitor installing dimensions as below.

- 75mm×75mm pitch
- 100mm×100mm pitch

TM complies with the VESA standard 100mm×100mm.

2.4 Wiring

Be sure no power is supplied when wiring and connecting to avoid the risk of electrical shocks. Do not turn the power on until all connections have been made. Prepare the cables to be used according to the specifications.

2.4.1 Wiring of Power Supply

■Compliant DC plug specifications

●DC Plug with screw lock

Outer diameter: $\Phi 5.5\text{mm}$, Inner diameter: $\Phi 2.1\text{mm}$, Screw lock: 5/16-32 UNEF-2B

Allowable voltage: 12V or more, Allowable current : 5A or more

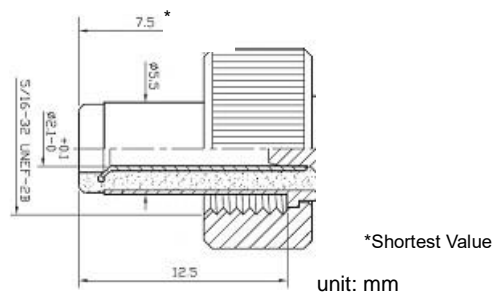

●DC Plug without screw lock

Outer diameter: $\Phi 5.5\text{mm}$; Inner diameter: $\Phi 2.1\text{mm}$

Allowable voltage: 12V or more, Allowable current : 5A or more



■Power Supply Wiring Precautions

- (1) Be sure to wire separately the power supply, input/output equipment, and the power equipment of the TM.
- (2) Do not bundle nor bring close together the main circuit line (high voltage, high current), signal line, and power cable.
- (3) Attach a ferrite core to the power cable if affected by noise.
- (4) Connect a lightning surge absorber if necessary.

■Grounding Precautions

- (1) FG should be dedicated grounding. "Installation should be D-class grounding, grounding resistance of 100Ω or less."
- (2) SG (Signal Ground) and FG (Frame Ground) is connected internally inside the TM. When connecting the connecting device and the SG, design the system so that there is no short circuit loop.
- (3) Use a grounding wire of 2mm^2 or more. The grounding point should be near the TM at shortest length. If ground wire becomes long, use a thick insulation wire when setting.
- (4) The TM will be FG grounded if the VESA arm is grounded to FG because the VESA arm surface is conductive.

2.4.2 Wiring Procedure

- (1) You will need a “USB Cable” and a “Video Interface Cable” in order to connect to a computer.
- (2) Make sure that the TM and the computer to which it is connected are not powered.
- (3) Connect the TM and the computer as show in in below diagram.

*Connect to the power supply last.

*Attaching a ferrite core to each cable may be effective against noise.

Model	Image Interface Cable	USB Cable
TMG-156FH01-01 TMH-156FH01-01	HDMI	USB3.0 or USB2.0

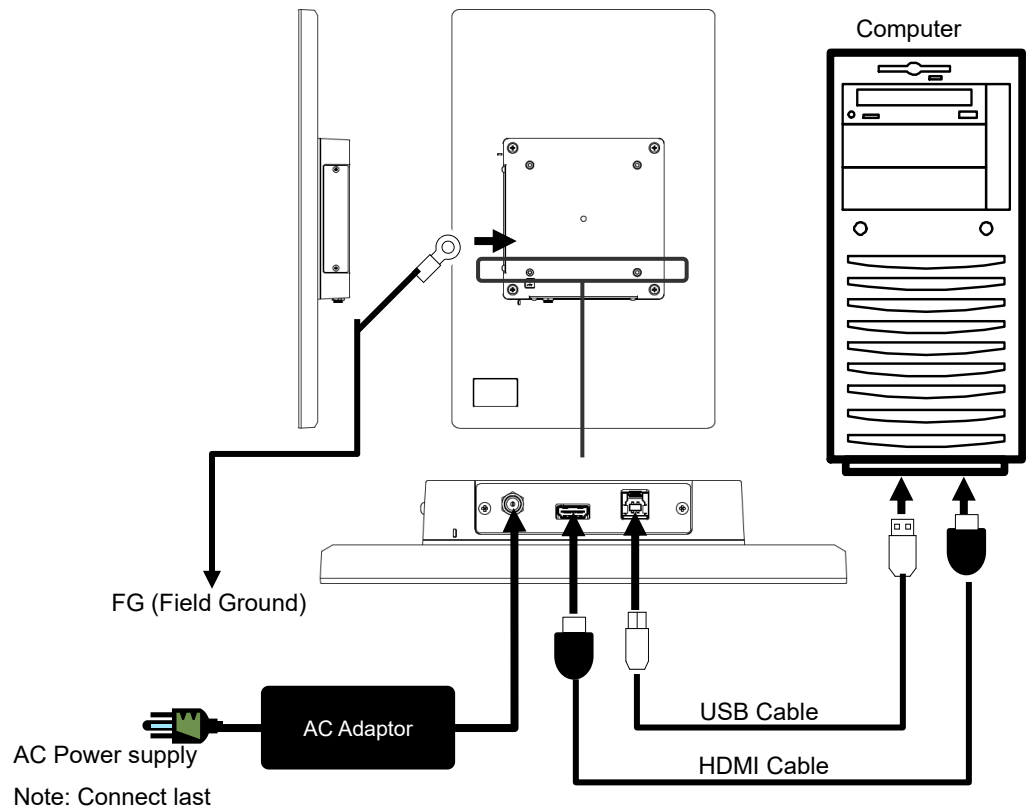

- (4) Standard orientation of the TM is vertical display installation. Set the TM display orientation to “portrait (opposite orientation)” in the computer setting.
- (5) For TMH-156FH01-01, refer to [4.4.2 Resistive Touchscreen](#) and click the box in front of “Use EEPROM” to register.
- (6) Calibration is not necessary for the TM in the factory default state. In case of touch coordinate misalignment or unstable touch operation, please refer to [4.4 Calibration](#) and perform calibration.
- (7) Resetting of the touch coordinate (rotation) of the touchscreen is not necessary. However, if the touch coordinates are rotated, please refer to [4.3.4 Touch Coordinate Rotation](#) and rotate the touch coordinates.

2.4.3 Rotating the VESA Box

The VESA box at shipment from the factory is oriented so the image interface is in the longitudinal direction.

Video interface can be rotated and changed by the customer.

■ Rotating the VESA Box

- (1) Turn off the power of the main unit and disconnect any peripheral devices connected to the TM.
- (2) Place the main unit on a flat and stable surface, such as a desk, with the display side facing down.
[Caution] Please be careful not to damage the display surface.
- (3) Remove the four screws securing the VESA box.

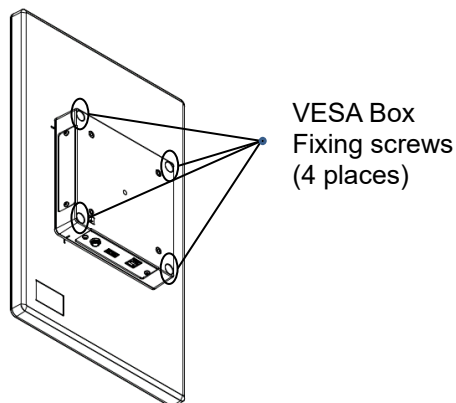

[Caution] Please be careful not to drop the screws inside the main unit and/or lose them.

- (4) Lift the VESA box gently about 1 to 2cm.

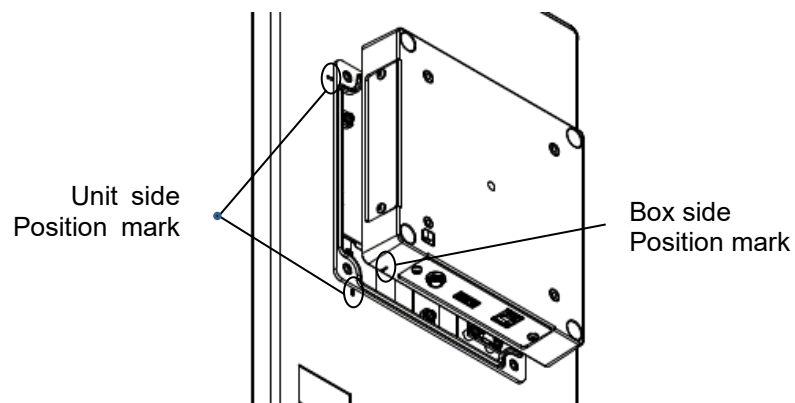

[Caution] Lifting the VESA box too high may break or damage the wires.

- (5) Rotate the box 90 degrees clockwise so that the position marks on the body side and the position marks on the box side are aligned.

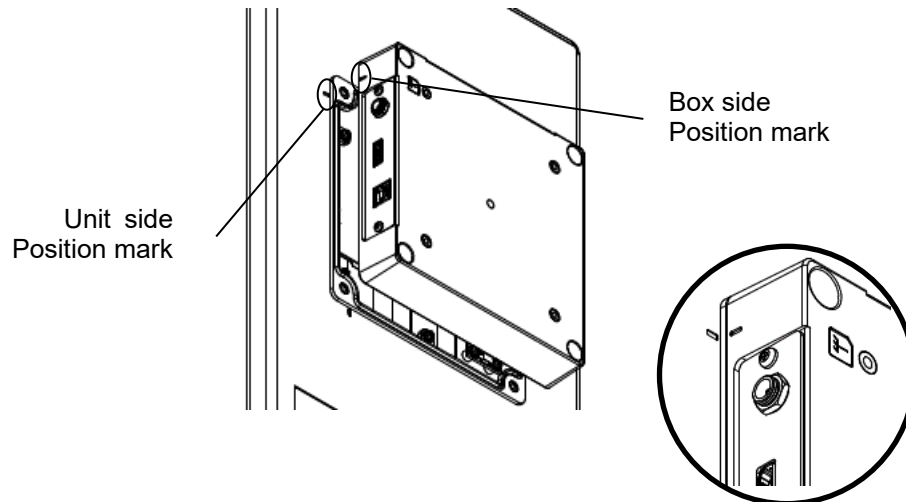

[Caution] Rotating more than 90 degrees may cause disconnections or damages.
Attempting to forcibly remove the VESA box may break or damage the wires.

- (6) Gently place the VESA box over the main unit so that there is no gap between the main unit and the VESA box.
Screw in four places with the four VESA box fixing screws removed from the VESA box in step (3). (Installation torque: 0.7 to 0.8N-m).

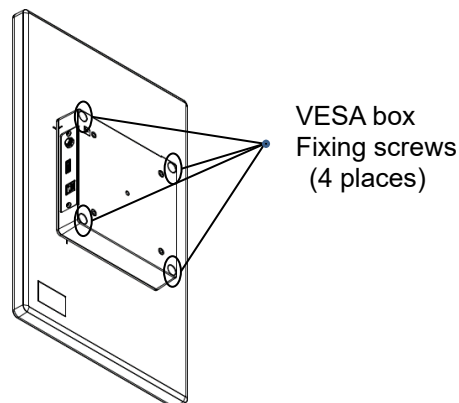

[Caution] Make sure that wires are not trapped between the box and the main unit.
If a screw is lost, make sure it is not inside the main unit.
If power is turned ON with the screw inside the unit, it may cause a malfunction.
(VESA box set screw: (+) pan head machine screw W-Sems diameter M4*8 NI plated)

- (7) After rotating the direction of the interface, turn on the main unit and set the computer display (landscape view) and make sure the display is working correctly.
(8) If touch operation is unstable, perform calibration referring to [4.4 Calibration](#).
(9) There is no need to reset the touch coordinates (rotation) of the touch screen. If the touch coordinates are rotated, please refer to [4.3.4 Rotation of Touch Coordinates](#) "to rotate the coordinates.

[Caution] Rotate the VESA box 90 degrees counterclockwise to return the interface direction from the horizontal position to the shipped position (down position).
Rotating the VESA box more than 90 degrees may cause wire disconnection or damage.

3. OSD

OSD (On Screen Display) should be used with default factory setting.
OSD cannot be changed by the customer.

Chapter Contents

3.1	OSD Menu (Factory Default Setting)	15
-----	--	----

3.1 OSD Menu (Factory Default Setting)

Menu	Adjustment range	Factory Default Setting	Contents
Brightness	0 ~ 100	80	Screen brightness adjustment
Contrast	0 ~ 100	50	Screen contrast adjustment
Sharpness	0 ~ 4	2	Screen sharpness adjustment
Gamma	OFF 1.8 2.2 2.4	OFF	Gamma value adjustment
Color Temp	5800K 6500K 7500K 9300K sRGB	6500K	Color temperature adjustment
	User		R/G/B Each adjustment range: 0~255
Color Effect	Standard Dynamic Movie Photo Vivid	Standard	Color effect adjustment
	User		R/Y/G/C/B/M Each adjustment range:0~100

4. Touch Screen Properties

Please download the “Touchscreen Driver (DMT-DD)” from the following URL: <https://www.dush.co.jp/english/download/driver-app/>

Chapter Contents

4.1	System Requirements	17
4.2	Installation	18
4.3	Setting	22
4.4	Calibration	27

* “Touchscreen Driver (DMT-DD)” V2.14 or later version is recommended.

* Please refer to the documents included in the “DMT-DD” for detailed instructions of “Touchscreen Driver (DMT-DD)”

4.1 System Requirements

4.1.1 System Configuration

Supported OS: Microsoft® Windows® 10/11 (32bit/64bit) Home Edition or higher.

4.1.2 Installation Requirements

- Software
Microsoft® .Net Framework 4.6 must be installed.
- Hardware
Requires about 10MB of free space in the system drive and data file storage space.
Installation location is as follows
For 32bit: System Drive¥Program Files¥DMT-DD
For 64bit: System Drive¥Program Files (x86) ¥DMT-DD
- Signature Algorithm
OS must support SHA-2 signature algorithm.

4.1.3 Remarks

- “Touch support (restrictions may apply)” may be displayed in the system property.
- For use with other OS other than those supported, please contact us.

4.2 Installation

4.2.1 Installing “Touchscreen Setting Tool (DMT-DD)”

- (1) Decompress the driver zip file downloaded to your computer.
*Do not connect TM to a computer via USB before installation.
- (2) Double-click "DMT-DDSetup.msi" or "DMT-DDSetup_ms.msi" inside the folder.
- (3) The setup wizard will start. Click [Next] to begin the installation.

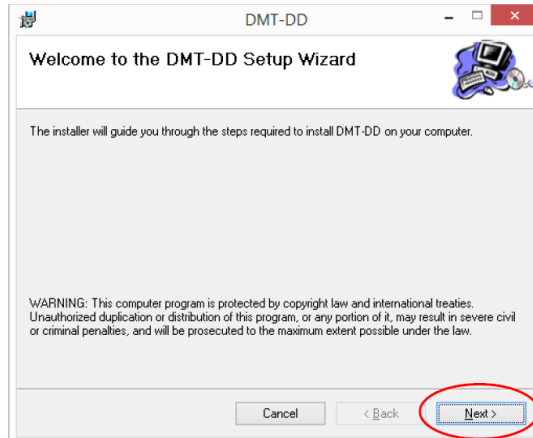

- (4) Review the license terms and select "I agree," and click [Next].

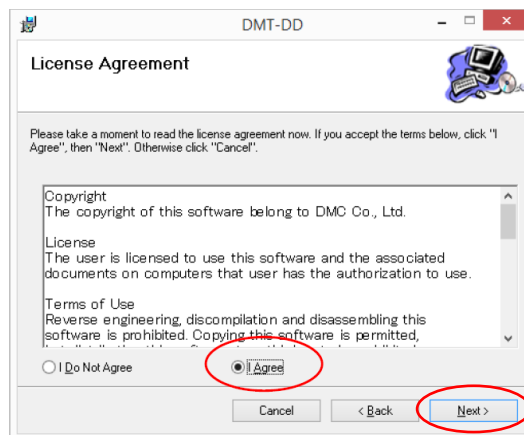

- (5) Click [Next] at “Confirm installation”.

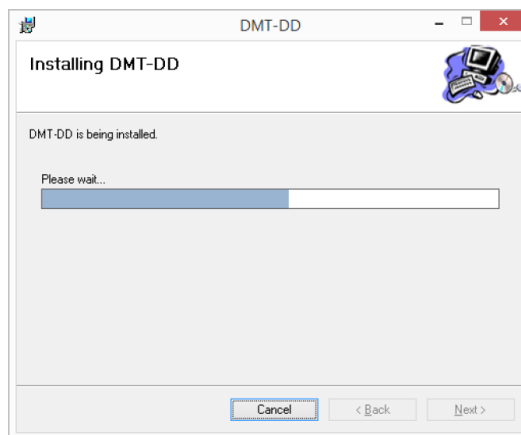
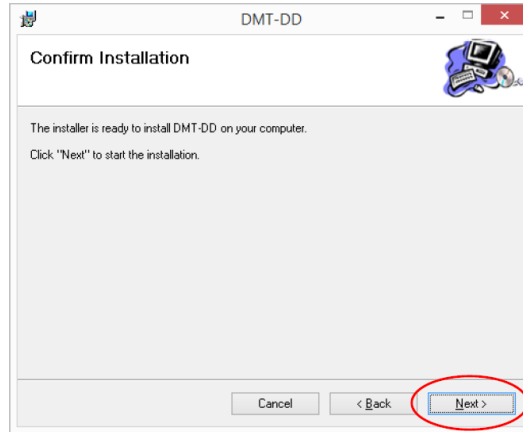

- (6) The following dialog may appear multiple times during installation. Click [Install]

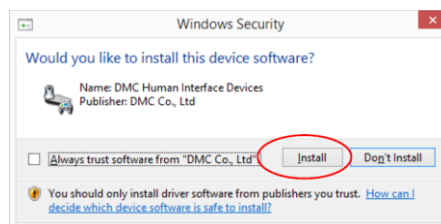

- (7) Click [Close] to complete the installation.

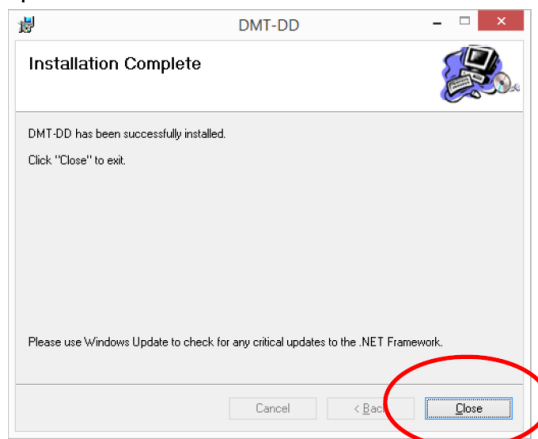

4.2.2 Installing the Touchscreen Driver

- (1) Connect TM and the computer with an USB cable.
The driver will be installed automatically when the USB cable is connected with the DMT-DD installed.
- (2) Start the "Touchscreen Driver" from the [DMT-DD] shortcut on the desktop.



- The setting tool **requires administrator privilege** to install drivers and etc.
Below dialogue might appear depending on the setting of UAC (User Account Control).
Click [Yes] to start.

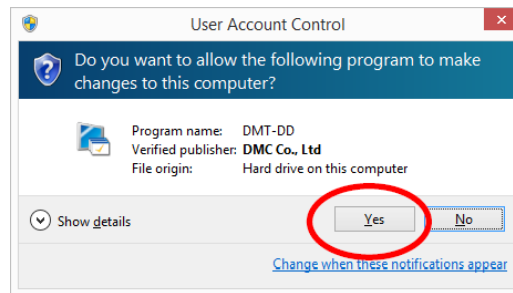

- (3) When the startup is complete [Device Addition] screen will appear.
Select [USB Port] from the [Touch Panel Device List] and click [Install].

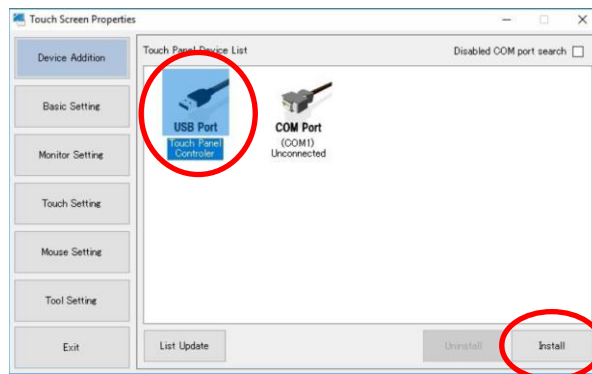

- (4) Installation confirmation dialog will appear. Click [YES].

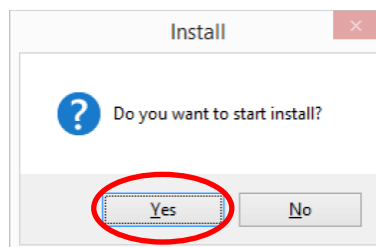

- (5) The below dialog will appear at initial installation. Click [Install].



- (6) The below window will appear. Click [OK] and restart your computer.

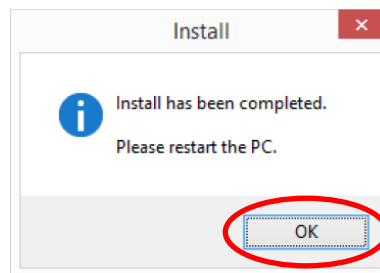

- (7) After restarting your computer, start "DMT-DD".
If the [USB Port] is changed to [TP Driver], the driver installation is complete.

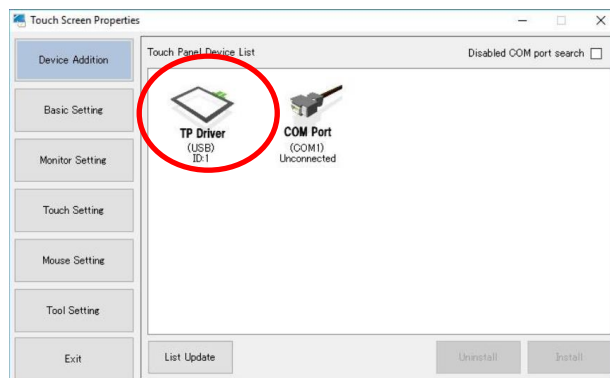

4.3 Setting

4.3.1 Monitor Setting

The below must be performed when using in a dual-display environment.

- (1) Click [Monitor Setting] and open the below screen.

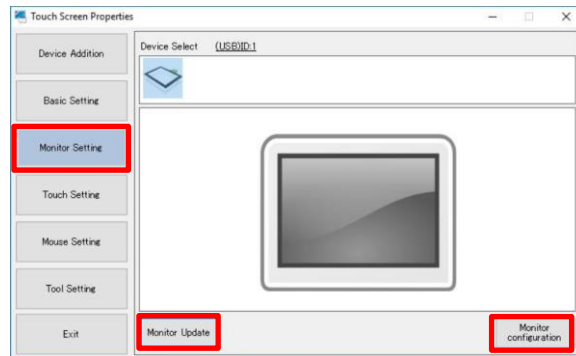

- (2) Click [Refresh Monitor] and refresh the connected monitor.
(The number of icons displayed will change depending on the number of monitors connected.)
- (3) Click [Monitor Configuration] and a dialog, "Confirm keyboard connection" will pop-up. Make sure the keyboard is connected and click [Yes]
- (4) The following screen will be displayed from the monitor on the leftmost

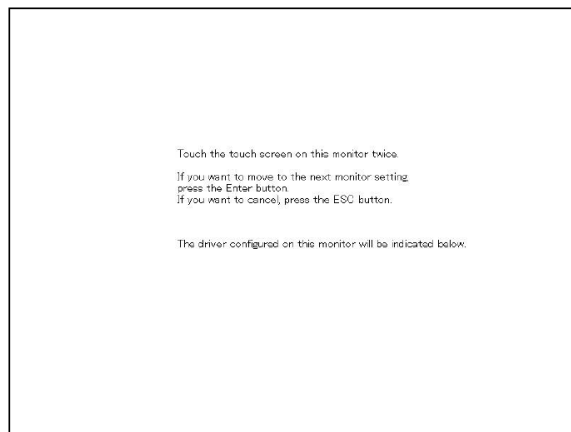

- (5) Press [Enter] until the above screen appears on the touchscreen monitor.
- (6) When the above screen appears on the touchscreen monitor, touch the indicated monitor twice.

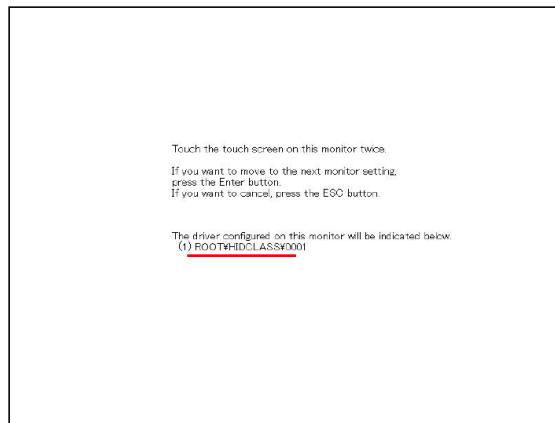

- (7) Press [Enter] after confirming the driver in red underline had appeared as shown above. If there are multiple monitors, screen displayed in (4) will be appear
- (8) Enter [Enter] on the last monitor and the setup is complete. If you wish to cancel during the process, press the “ESC” key.
- (9) The monitor associated with the selected driver will become active and the driver ID is displayed.

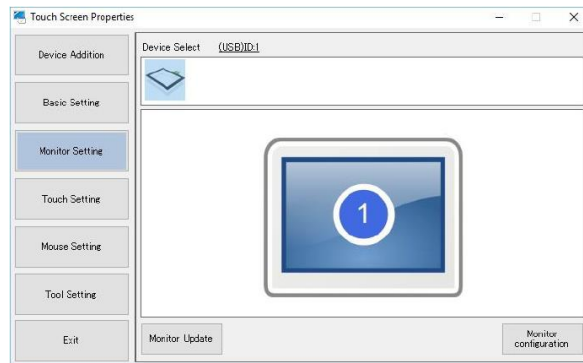

4.3.2 Touch Setting

The below screen will be displayed only when OS later than Windows7 is used.

- (1) Click [Touch Setting] and open the following window.

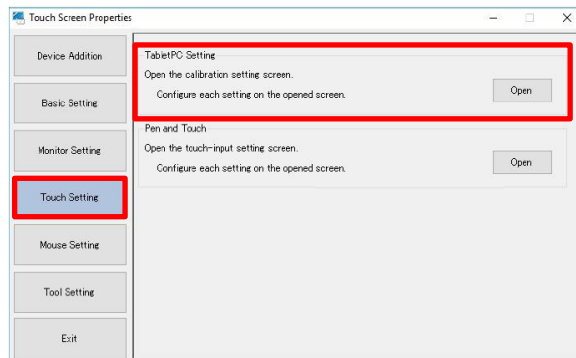

- (2) Click [Open] of [Tablet PC Setting] to open Windows standard setting.

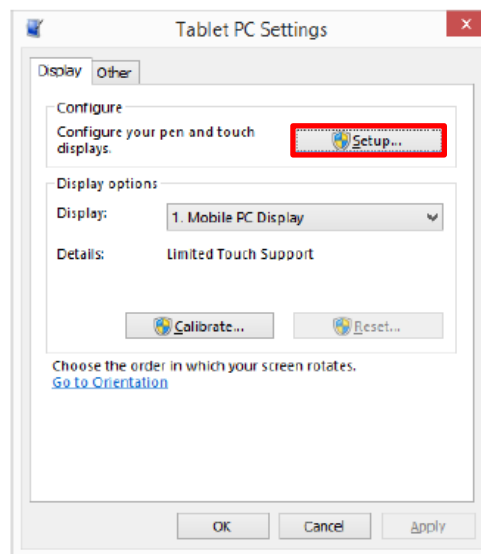

- (3) Click [Setup] under [Configuration] and the following screen will appear.



- (4) Press [Enter] until the above message is displayed on the monitor to be equipped with the touchscreen.
- (5) When the message is displayed on the monitor to be equipped with the touchscreen, tap the screen as instructed.
- (6) If there are multiple monitors to equip with the touchscreen, perform the above process (5) to all the touchscreen monitors.

4.3.3 Touch Format

Touch data mode can be set for the driver selected in the combo box.

- (1) Click [Standard setting] and select the [Touch Input Setting] tab.

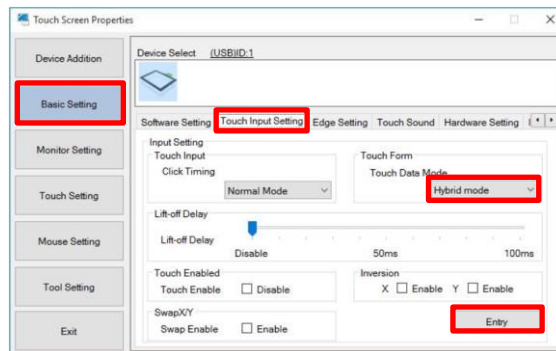

- (2) Set the [Touch Data Mode] of [Touch Format] as below.

- Serial Mode: Outputs touch data in serial format
- Hybrid Mode: Outputs touch data in parallel format

Select Hybrid Mode.

Default setting: Serial Mode.

* Please reboot the computer whenever the setting is changed.

4.3.4 Single Touch Setting

The Setup file is not registered by default and is set as “touch output”. When using single-touch, change to “mouse output” by the following procedure.

- (1) Start [Touch screen Properties]
- (2) Open [Configuration file] via [Basic Setting]
- (3) Select [Mouse.mfd] and click [Register]

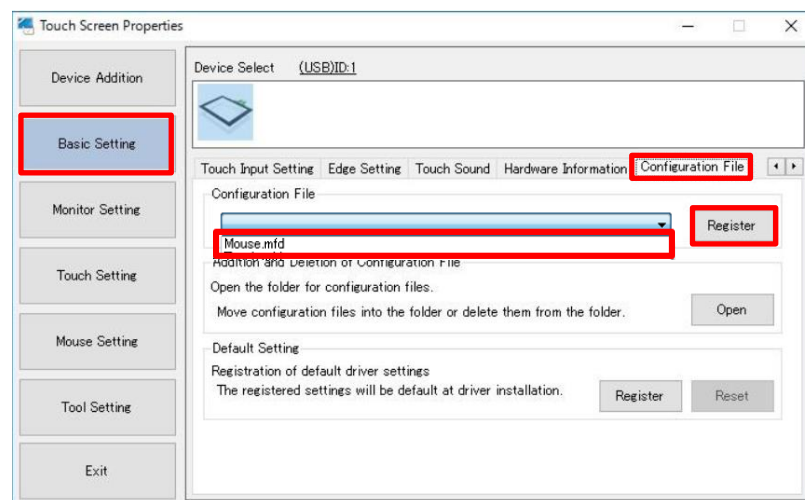

4.3.5 Multi-Touch Setting

When using multi-touch, set “Touch Output” by the following procedure.

- (1) Start [Touchscreen Properties]
- (2) Open [Configuration file] via [Basic Settings]
- (3) Select [Touch.mfd] and click [Register]

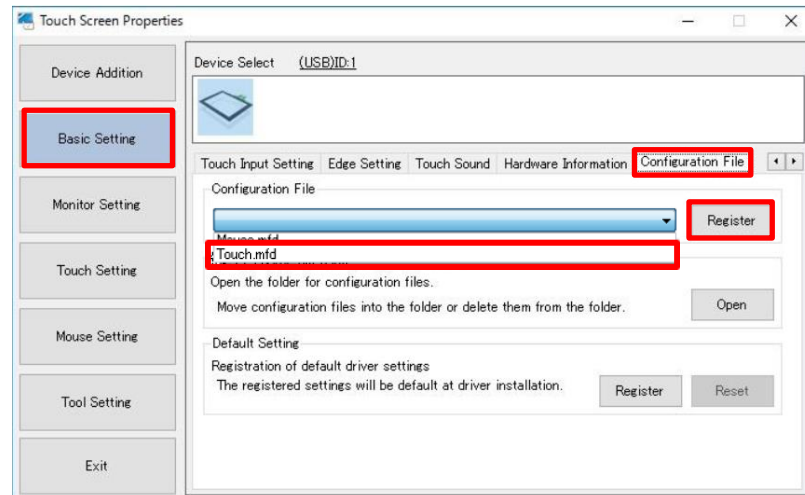

4.3.6 Rotating Touch Coordinates

The XY coordinates output by touch operation can be rotated 0, 90, 180 and 270 degrees.

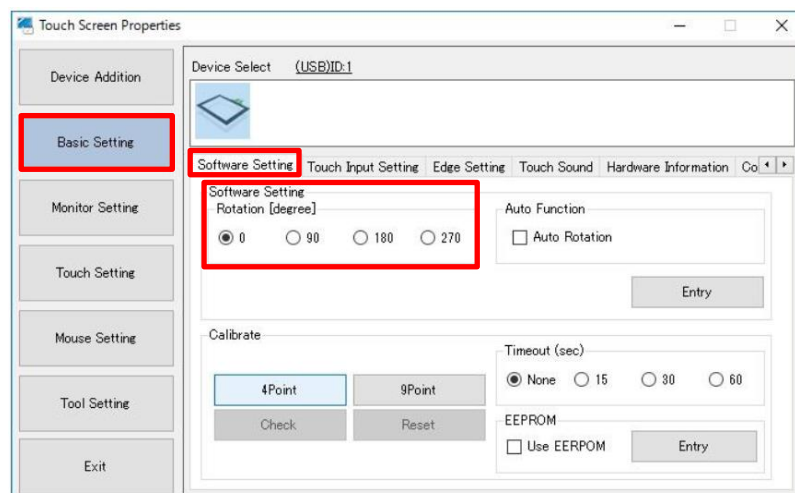

4.4 Calibration

The touchscreen operation may become unstable depending on the installation environment due to the characteristics of the touchscreen. In order for the touchscreen to be used correctly, please perform calibration after installation.

4.4.1 Projected Capacitive Touchscreen

[TP Offset] -Sensitivity calibration

- (1) Start [DMT-DD]
- (2) Open [Touch screen Maintenance] via [Basic Setting] > [Hardware Setting] and click [Open].

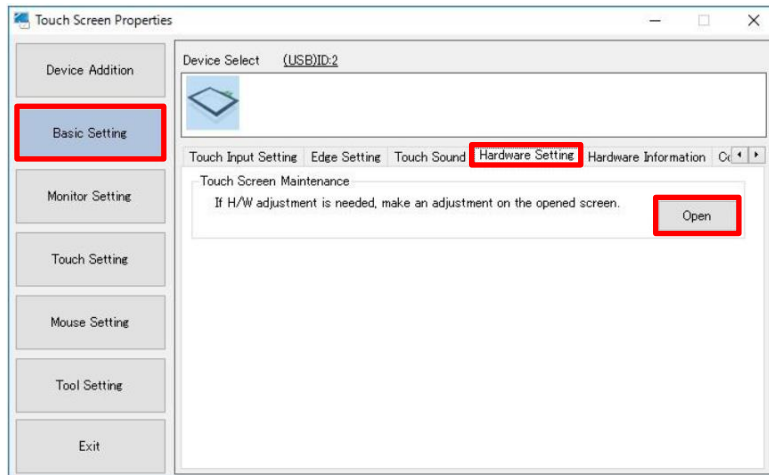

- (3) Hardware calibration is complete when [Dev.0] [DONE] [0x00] turns green.

Maintenance Tool Screen (Example)

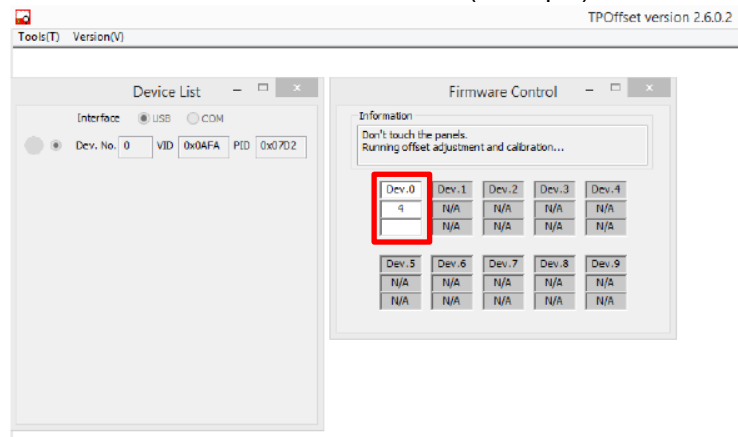

- *[Setup Tool] cannot be operated while the [Maintenance Tool] is running.
- *Please do not touch the touchscreen when calibration is being performed.
- *This tool will automatically terminate.

4.4.2 Resistive Touch Screen

[4 Point Correction] or [9 Point Correction]- Coordinate Calibration

- (1) Start [DMT-DD].
- (2) Choose the [Software Setting] via [Basic Setting].

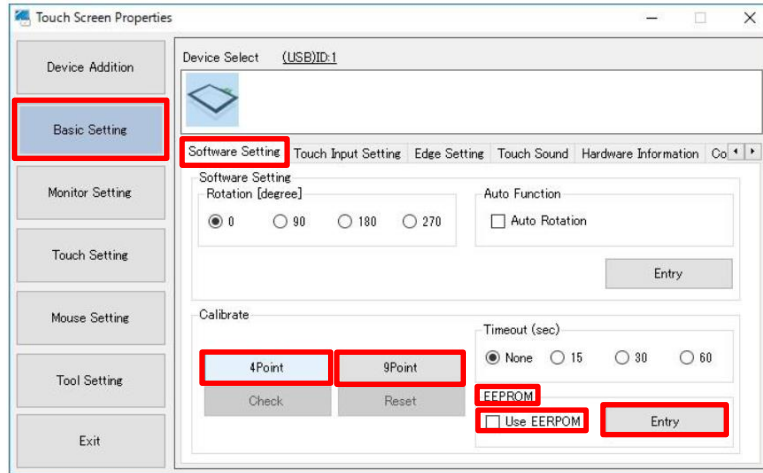

- (3) Click and place a check in the box next to [Use EEPROM] under [EEPROM] and click [Entry].
When [4 Point] or [9 Point] correction is performed with the check in the box, the correction data will be stored in the EEPROM of the TM.
When performed without the check, then the correction data will be stored inside the computer.
[4 Point] correction is conducted to the TM at shipment from the factory and the correction data is stored in the EEPROM.
Placing the check will recall the data from the EEPROM and correction will not be necessary.
If touch coordinates are out of alignment, please follow the procedure below and perform coordinate calibration.
When correction is performed without placing the check, the correction data at factory shipment will not be reflected and accurate touch operation may not be possible.
- (4) Below adjustment screen will be displayed when [4 Point] or [9 Point] is clicked.

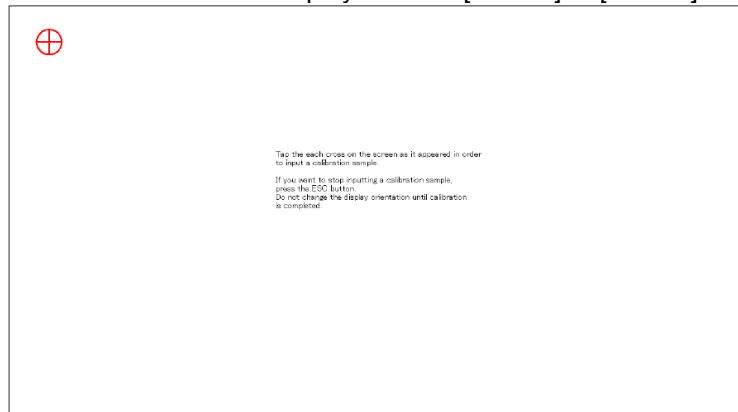

- (5) Touch the center of the marker displayed on the screen and another marker will appear one after another. Do the same for all.
- (6) After all markers have been touched, adjustment is complete, and the following screen will appear:

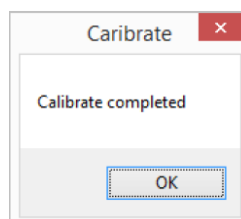

- (7) Click [OK] and finish the adjustment.

4.4.3 Gesture Correction (DO NOT PERFORM)

When gesture operation is not responding smoothly, it may improve with [Gesture Correction]. [Gesture Correction] is performed at factory shipment and does not need to be performed. If [Gesture Correction] is performed, touch operation may not operate normally.

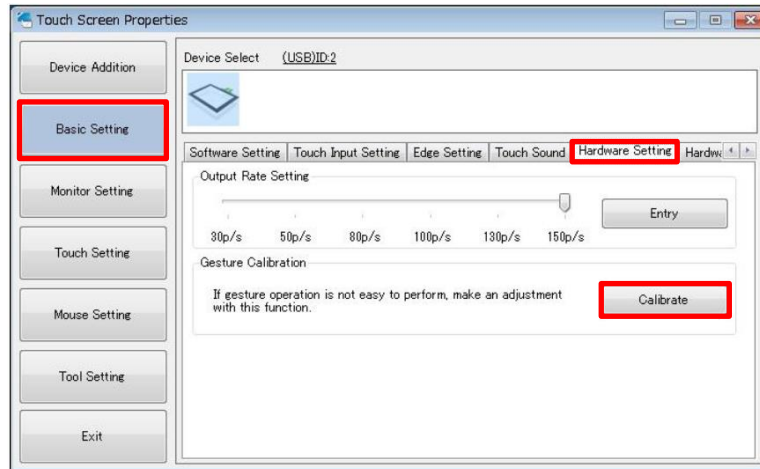

5. Maintenance

Chapter Contents

5.1	Maintenance.....	31
-----	------------------	----

5.1 Maintenance

5.1.1 Caring for Display

If the display surface or the frame becomes dirty, wipe with a soft cloth soaked in mild neutral detergent and wrung tightly.

- ⊘ Use of thinner, organic solvents, and strong acidic detergents are prohibited.

5.1.2 Periodic Check

To keep the product in its best condition, please check periodically.

□ Ambient Environment Check

- (1) Ambient temperature is within specified range (0~40°C).
- (2) Ambient humidity is within specified range (10 ~ 80%RH (No condensing, wet-bulb temperature is 39°C or below)).
- (3) Operating pressure is within specified range (800~1114hpa).

□ Electrical Specification Check

- (1) Voltage is within the permissible range (DC12V±10%)

□ Installation Condition Check

- (1) Connectors of the cables are fully and securely inserted.
- (2) VESA mounting fixtures are securely installed and are not loose.

6. Troubleshooting

If symptoms persist after taking corrective actions, consult your distributor or contact us (refer to "[7.3 Inquires](#)").

Chapter Contents

6.1	Display Display	33
6.2	Touchscreen	34

6.1 Display

No	Symptoms	Causes/ Measures
1	<ul style="list-style-type: none">• Screen not displayed	<ul style="list-style-type: none">• Make sure the power cord is inserted securely.• Make sure the image signal cable is connected properly.• Make sure the power of the computer is on.• Check and see if the computer image output is correct.
2	<ul style="list-style-type: none">• Afterimages appear	<ul style="list-style-type: none">• Afterimages can be seen if the same image is displayed for a long period of time. Use the screensaver or the OFF-timer function to avoid image burn-ins.
3	<ul style="list-style-type: none">• Red, green, blue, and/or white dots remain on the display.• A defective dot (does not light up) is on the display.	<ul style="list-style-type: none">• This is a characteristic of the LCD panel and not a malfunction.

6.2 Touchscreens

No	Symptom	Causes and Measures
1	<ul style="list-style-type: none"> • Cursor position is not correct • Cursor jumps 	<ul style="list-style-type: none"> • Unplug and plug the USB cable connected to the computer. • Make sure the FG (Frame GND) of the TM and the FG (Field GND) of the power supply are connected. • Place a check in the checkbox of EEPROM. Please refer to "4.4.2 Resisteive Touchscreen" for details • Perform touchscreen calibration. Please refer to "4.4 Calibration" for details.
2	<ul style="list-style-type: none"> • Touch operation is not effective. 	<ul style="list-style-type: none"> • Make sure the USB cable connected to the computer is properly and securely connected. • Reboot the computer. • Make sure the touchscreen driver is properly installed.
3	<ul style="list-style-type: none"> • No touch sound. 	<ul style="list-style-type: none"> • Touch sound may not be output depending on the computers configuration. • Please choose whether to make touch sounds or not by using the touchscreen driver.

7. Others

Chapter Contents

7.1	Warranty and Repair.....	36
7.2	Production Discontinuance	37
7.3	Inquiries	38

7.1 Warranty and Repair

7.1.1 Warranty

The warranty period is limited to 12 months from the date of shipment. Any defects that occur under the environmental conditions noted within the specification will be repaired free of charge (factory repair).

The warranty for repair needed to the same repaired area is limited to three months.

You will be liable for all repair fees even within the warranty period for any conditions listed below.

- (1) Malfunctions and/or damages caused by dropping or impact during transportation and transferring of the product after delivery.
- (2) Malfunctions and damages caused by natural or human-made disaster.
- (3) If the product is used under any condition, environment, or method other than those described in the product specification, catalogs, manuals, or others.
- (4) Replacement of consumables.
- (5) Malfunctions, defects, and/or damages caused by associated equipment and/or usage of inappropriate consumables and media.
- (6) If the product is repaired, remodeled, modified, or disassembled by a party other than DMC, or if the serial number cannot be confirmed.
- (7) Malfunctions, defects, and/or damages that are to have been caused by the customer.

The warranty covers only the delivered product. Damages, onsite repairs and replacements driven by the failure of the product will be decided upon discussion by both parties as necessary.

7.1.2 Repair Conditions

- (1) Only DMC products can be repaired. Options are exempt.
- (2) Repairs will be performed in our factory workshop. All shipping costs to our factory will be charged to the customer.
- (3) DMC will have all ownership of the parts exchanged at repair.
- (4) Please note that failure cause analysis cannot be performed for LCD and touchscreens due to the configuration of the product.

7.1.3 Repair Inquiries

If you need have any questions regarding repairs for DMC products, please contact us and we will be glad to help.

When doing so, please confirm the issue or the symptom beforehand. Also, when shipping us your product, please enclose a fully filled repair request form describing the issue or the symptom and be sure to package the product carefully so that it will not be damaged by vibration during shipment.

7.2 Production Discontinuance

In the event of production discontinuance, an announcement will be made six months prior to the last possible order reception date.

7.3 Inquiries

For comments or inquiries, feel free to contact us via e-mail.

North South America area

✉ technical-global@dush.co.jp

Asia Pacific area

✉ technical-global-asia@dush.co.jp

Europe, Middle East, Africa area

✉ technical-global-eu@dush.co.jp

FAQ



www.dush.co.jp/english/support/faq/

Microsoft® Windows® is a registered trademark of United States Microsoft Corporation in the United States and other countries. Other product and company names mentioned herein are trademarks or registered trademarks of their respective owners.

3rd Edition June 2024

Published by DMC Co., Ltd.

Office hours: 9:00a.m to 5:00 p.m. (JST)

(Except Saturdays, Sundays, national holidays, and year-end and New Year holidays)

URL: <https://www.dush.co.jp/english/>

This product and document are protected by the copyright law. Photocopying, duplicating, reproducing, and modifying of this product or document in part or by whole is prohibited.

Copyright(C) 2024 DMC Co., Ltd. All Rights Reserved