

**DMC Co., Ltd.**

**Analog Resistive Touch Screen Controller IC with Gesture Function  
TSC-52/IC Product Specification**

## Table of Contents

<b>1. Product Outline</b> .....	<b>2</b>
1.1 Scope of Application .....	2
1.2 Outline .....	2
1.3 Features .....	2
1.4 General specification .....	3
1.5 Supported Sizes of Touch Screens .....	4
1.6 Gesture function .....	4
<b>2. Terminal assignment &amp; Marking</b> .....	<b>5</b>
2.1 Terminal assignment .....	5
2.2 Marking .....	5
<b>3. Terminal function description</b> .....	<b>6</b>
<b>4. Host interface</b> .....	<b>7</b>
4.1 USB Interface .....	7
4.2 Serial Interface .....	7
<b>5. Electrical characteristics</b> .....	<b>8</b>
5.1 Absolute maximum ratings .....	8
5.2 DC Characteristics .....	9
5.3 Timing requirements .....	10
<b>6. Packaging specification</b> .....	<b>12</b>
6.1 Outline .....	12
6.2 Notes on storage and handling .....	12
6.3 Basic packaging .....	12
6.4 Small-quantity-packaging .....	13
6.5 Tray specification .....	14
6.6 Model name indication specification .....	14
<b>7. Storage specification</b> .....	<b>14</b>
7.1 Storage condition .....	15
7.2 Baking .....	15
<b>8. Mounting specification</b> .....	<b>16</b>
<b>9. Terminal specification</b> .....	<b>17</b>
<b>10. Warranty</b> .....	<b>17</b>
10.1 Warranty period .....	17
10.2 Warranty scope .....	17
10.3 Warranty Exceptions .....	17
<b>11. Notes on use</b> .....	<b>17</b>
11.1 Overall handlings .....	17
11.2 Others .....	18
<b>12.Revision history</b> .....	<b>18</b>

## Attached documents:

- 1) Outline Dimensions for IC package
- 2) Recommended Circuit

## **1. Product Outline**

### **1.1 Scope of Application**

This product specification applies to LQFP type Controller IC called TSC-52/IC equipped with 2-finger inputting gesture function for 4-wire Resistive Touch Screen.

### **1.2 Outline**

#### 1.2.1 Unique functions

This is the IC to be used to realize gesture functions with 2-finger such as flick, pinch-in/pinch-out, rotation along with recommended circuit for 4-wire resistive Touch Screen.

#### 1.2.2 Basic function of controller's

This is the controller IC to transform analog signals from 4-wire Touch Screen into coordinates data of 10-bit resolution using AD conversion and then send them to host computer. Filtering processing function in the IC during detecting coordinates data enables to obtain stable coordinates data. Also using compensation function on the host computer side can compensate the coordinate deviation between an input point on Touch Screen and a point of cursor indication and make them match to the one point.

### **1.3 Features**

- \*This IC is equipped with the function of "Coordinate data mode" that can transmit the read data at the rate of 150-point/s with the resolution of 10-bit.
- \*With USB connection, the IC is correspondent with USB suspension mode while it can be recovered by external cut-in input signal into Touch Screen.
- \*During 2-point inputting, the IC enables to detect the locations of the two(2) points and enables pinch in/pinch-out and rotation when the two(2) points moved with the inputs kept by measuring the change in voltages.
- \*Coordinate calibration data can also be saved into EEPROM in TSC-52/IC.

1.4 General specification

Items		Ratings	Remarks
Supply Voltage		5V DC ± 5%	
Consumption Current		50 mA typ. 1 mA typ. at sleeping mode	
Operating Temperature		-40°C to +105 °C No condensation	
Storage Temperature		-55°C to +150°C No condensation	
Communication scheme (serial)	Communication scheme	Asynchronous, UART	Each setting is fixed
	Communication rate	9600bps	
	Data length	8bits	
	Stop bit	1bit	
	Parity	None	
Communication Method (USB)	Transfer Speed	USB Specification 2.0 Full Speed	
	Transfer Mode	Interrupt Transfer (Coordinates)	
Operating Frequency		16 MHz	Internal CPU 72 MHz
Coordinates output rating (points/s)		150 p/s	
Linearity error		±3 LSB	
Input Response Time		10 ms typ.	150p/s at coordinates data mode
Coordinates Resolution		10 bit (1024 x 1024)	
2-point Input Resolution		Min. 2-point input-able distance: 7mm typ. After gesture calibration : 4mm typ.	with LST-121B080A (12.1in) *Refer to the graph shown below
Outline Dimensions(mm)		9.0 x 9.0 x 1.7	

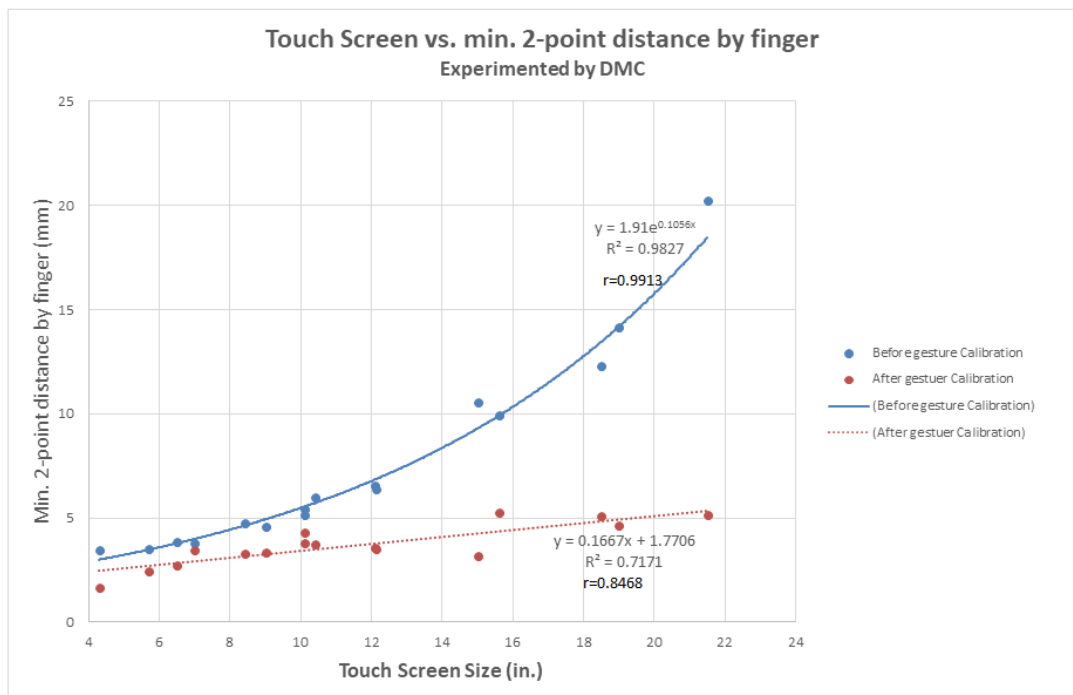

### 1.5 Supported Sizes of Touch Screens

The supported sizes of touch screen are from 4.3inch Wide to 21.5inch Wide in DMC's 4-wire resistive touch screen lineups.  
(LST touch screen series is recommended)

### 1.6 Gesture function

(1) Pinch-in/Pinch-out

Pinch-out is defined as the motion that when 2 points are input, the distance between them moves bigger. While Pinch-in is defined as the motion that when 2 points are input, the distance between them moves narrower. There are two case in Pinch-in/Pinch-out as shown below.

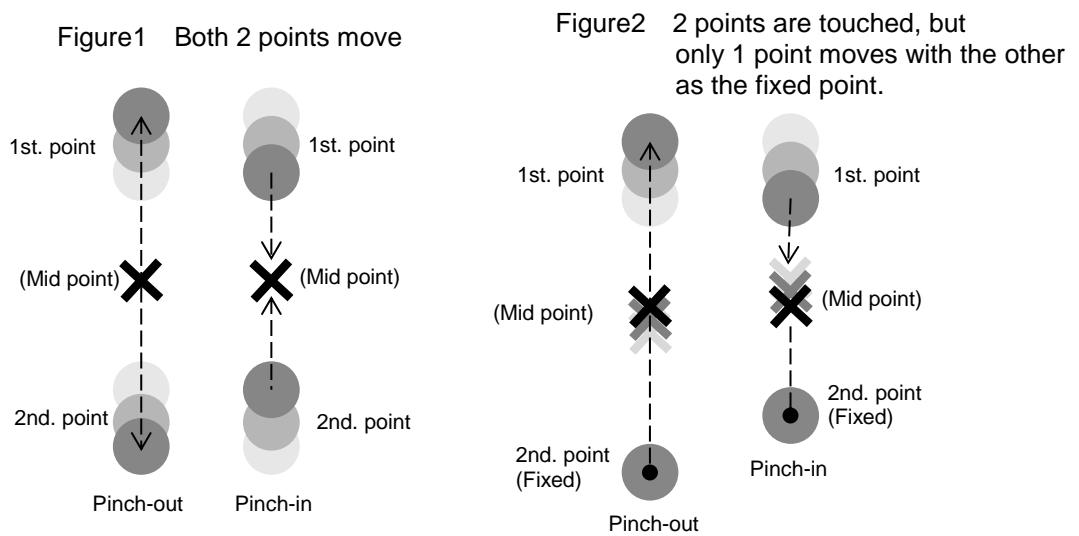

(2) Rotation

Rotation is defined as the motion that when 2 points are input, the both 2 points rotate clockwise or counter-clockwise with the mid point as center, and one point rotates with the other fixed as center.

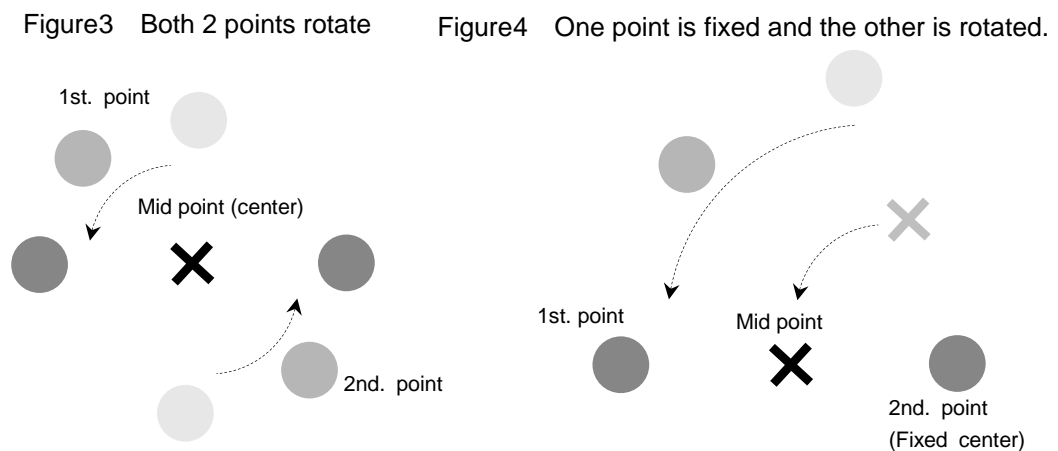

## 2. Terminal assignment & Marking

### 2.1 Terminal assignment

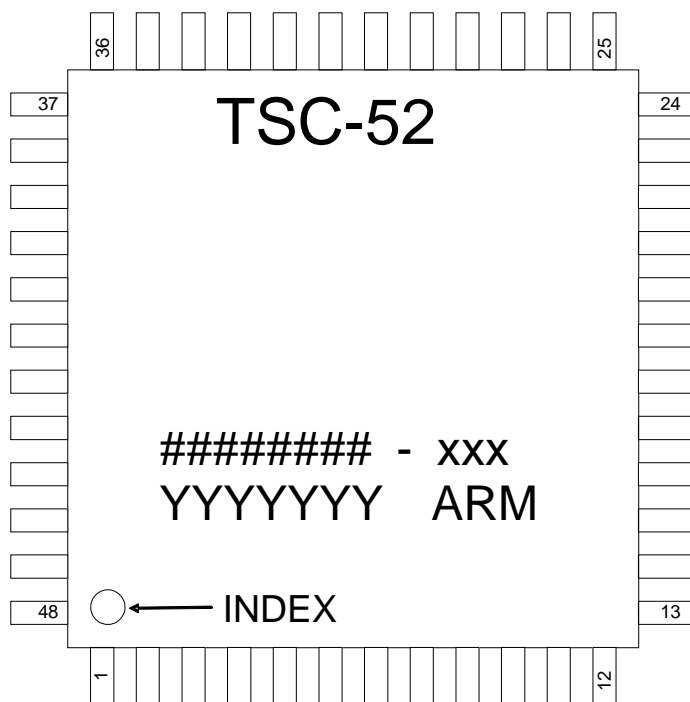

### 2.2 Marking

TSC-52: Product number

#####-xxx : Lot code

YYYYYYY : DMC's administration number

ARM : ARM CPU

## 3. Terminal function description

Terminal Numbers	Terminal names	I/O	Function descriptions
1	AD_YD	I	Input terminal at YD side for Touch Screen
2	AD_RUL	I	Connect to Output terminal of Op-Amp
3	AD_YU	I	Input terminal at YU side for Touch Screen
4	nRESET	I	Input terminal for Re-set signal (Active L)
5	PANEL_YD	O	Touch Screen control terminal
6	AVSS	I	Connect to Vss
7	PANEL_YU	O	Touch Screen control terminal
8	PANEL_XR	O	Touch Screen control terminal
9	PANEL_XL	O	Touch Screen control terminal
10	VBAT	I	Connect to VDD
11	LED0	O	LED output terminal. This terminal becomes L(Low) when initializing process is finished without problem.
12	LED1	O	LED output terminal. This terminal becomes L(Low) when input is given into Touch Screen, meaning Touch Screen is pressed down by finger.
13	LED2	O	Leave it open.
14	BEEP	O	Beep output terminal and this terminal outputs H(High) with signals of 2.5kHz/50ms when Touch Screen is pressed down.
15	XT1_OUT	O	Clock output terminal and leave it open when external output is used.
16	XT1_IN	I	Clock input terminal and Input clocks of 16MHz when external clock is used.
17	VSS	I	Connect to Vss.
18	LDO_CAP	I	Connect to Vss by way of a capacitor(1uF).
19	PANEL_THOa	O	Control terminal for detecting pen-down.
20	PANEL_THOb	O	Leave it open.
21	nAMP_SHDN	O	Connect to SHDN terminal of Op-Amp
22	SW1	O	Leave it open.
23	JP2	O	Leave it open.
24	JP4	O	Leave it open.
25	ICE_CK	I	Connect to VDD by way of a resistor.
26	ICE_DAT	I	Connect to VDD by way of a resistor.
27	PANEL_LL	O	Leave it open.
28	PANEL_UR	O	Leave it open.
29	PANEL_RUL	O	Control terminal for Touch Screen
30	PANEL_RUR	O	Control terminal for Touch Screen
31	VDDIO	I	Connect to VDD.
32	USB_VBUS	I	Connect to VDD.
33	USB_D-	I/O	USB D- terminal. In Serial mode, Leave it open.
34	USB_D+	I/O	USB D+ terminal. In Serial mode, Leave it open.
35	JP5	O	Leave it open.
36	USB_VDD33	I	Connect to Vss by way of a capacitor(1uF).

37	I2C_SCL	I	Connect to VDD by way of a resistor.
38	I2C_SDA	I	Connect to VDD by way of a resistor.
39	UART_RxD	I	In serial mode, data receive pin. In USB mode, connect to VDD by way of a resistor.
40	UART_TxD	O	In serial mode, data send pin. In USB mode, connect to VDD by way of a resistor.
41	VDD	I	Connect to VDD.
42	AVDD	I	Connect to VDD.
43	VREF	I	Reference voltage for A/D. Connect to VDD.
44	DA_BIAS	O	Connect to -(minus) terminal of Op-Amp.
45	JP9	I	Leave it open.
46	AD_RUR	I	Connect to Output terminal of Op-Amp.
47	AD_XL	I	Input terminal at XL side for Touch Screen
48	AD_XR	I	Input terminal at XR side for Touch Screen

## 4. Host interface

### 4.1 USB Interface

Items	Specifications
USB standard	Specification Rev.2.0 Full Speed
Power Supply	Bus supply voltage/Self power
Device Class	HID (Human Interface Device)
Cut-in (Coordinate) transfer interval	1ms

### 4.2 Serial Interface

Items	Specifications
Communication scheme	Asynchronous, UART
Communication rate	9600bps
Data length	8bits
Stop bit	1bit
Parity	None



## 5. Electrical characteristics

### 5.1 Absolute maximum ratings

Items	Symbols	Rated values		Units	Remarks
		Min.	Max.		
Supply Voltage	V <sub>DD</sub>	-0.3	7.0	V	V <sub>DD</sub>
Input Voltage	V <sub>I</sub>	V <sub>SS</sub> -0.3	V <sub>DD</sub> +0.3	V	
Maximum Current flowing into V <sub>DD</sub>	I <sub>DD</sub>	—	120	mA	I <sub>DD</sub>
Maximum Current flowing from V <sub>SS</sub>	I <sub>SS</sub>	—	120	mA	
Operating Temperature	T <sub>OPR</sub>	-40	+105	°C	
Storage Temperature	T <sub>STG</sub>	-55	+150	°C	

## 5.2 DC Characteristics

Unless otherwise specified,  $V_{DD}=2.5\sim 5.5V$ ,  $V_{SS}=0V(GND)$ ,  $T_a=25\text{ }^\circ\text{C}$

Items	Symbols	Rated Values			Units	Remarks
		Min.	typ.	Max.		
Supply Voltage	$V_{DD}$	4.75	—	5.25	V	
Analog Supply Voltage	$AV_{DD}$		$V_{DD}$		V	
Supply Voltage Ground	$V_{SS}$	-0.3	0	0.3	V	
Analog Reference Ground	$AV_{SS}$	-0.3	0	0.3	V	
“L” Input Voltage (Terminal number 21 to 26, 35, 37 to 39, 45)	$V_{IL1}$	-0.3	—	0.8	V	$V_{DD}=4.5V$
“H” Input Voltage (Terminal number 21 to 26, 35, 37 to 39, 45)	$V_{IH1}$	2.0	—	$V_{DD}+0.3$	V	$V_{DD}=5.5V$
“L” Output Voltage (Terminal number 5, 7 to 9, 11 to 14, 19, 20, 27 to 30, 40)	$V_{OL}$	—	—	0.45	V	$V_{DD}=4.5V$ , $I_{OL}=17mA$
“L” Output Voltage (Terminal number 5, 7 to 9, 11 to 14, 19, 20, 27 to 30, 40)	$V_{OH}$	2.4	—	—	V	$V_{DD}=4.5V$ , $I_{OH}=-26mA$
“L” Input Voltage (Terminal 16(XT1_IN))	$V_{IL3}$	0	—	0.8	V	$V_{DD}=4.5V$
“H” Input Voltage (Terminal 16(XT1_IN))	$V_{IH3}$	3.5	—	$V_{DD}+0.3$	V	$V_{DD}=5.5V$
“L” Input Voltage Schmitt (Terminal number 4(nRESET))	$V_{ILS}$	-0.3	—	$0.2V_{DD}$	V	
“H” Input Voltage Schmitt (Terminal number 4(nRESET))	$V_{IHS}$	$0.7V_{DD}$	—	$V_{DD}+0.3$	V	
Transmission Frequency	$X_{IN}$	—	16.0	—	MHz	at USB mode Transmission accuracy: $\pm 0.25\%$

5.3 Timing requirements

5.3.1 Power on Reset

Items	Symbols	Rated Values			Units	Remarks
		Min.	Typ.	Max.		
Temperature	Ta	-40	25	105	°C	
Reset Voltage	VPOR	1.6	2	2.4	V	
VDD Start Voltage	VPOR	—	—	100	mV	VDD Start Voltage to Ensure Power-on Reset
VDD Increase rate	RRVDD	0.025	—	—	V/ms	VDD Raising Rate to Ensure Power-on Reset
L width at Reset	tPOR	0.5	—	—	ms	Minimum Time for VDD Stays at VPOR to Ensure Power-on Reset

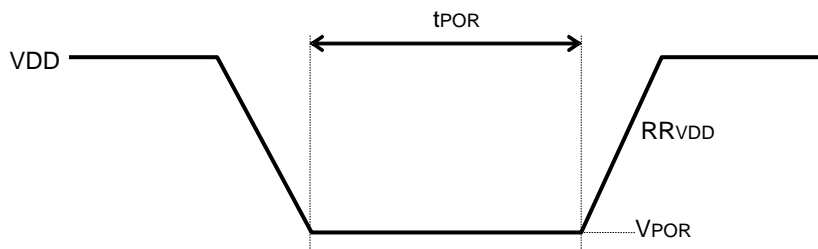

5.3.2 nRESET Reset

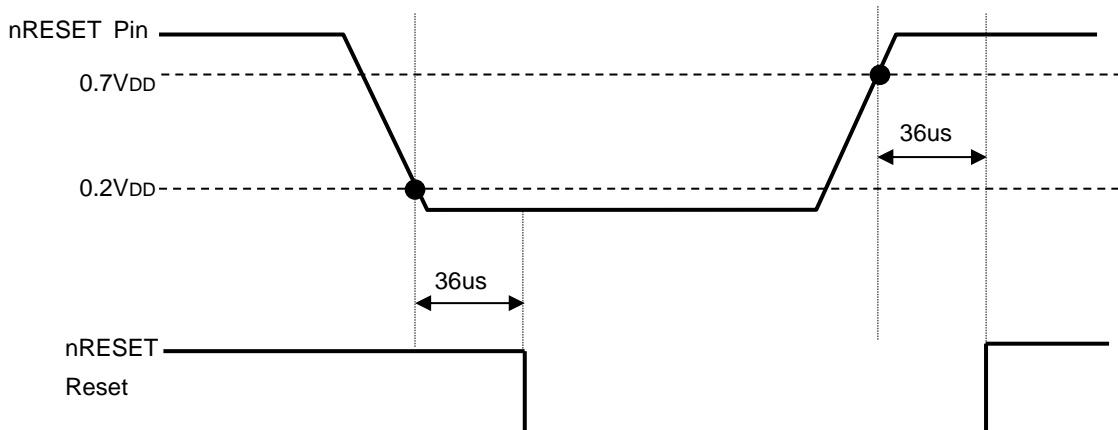

\*Input Low pulse width min. 36us

5.3.3 External clock timing

Items	Symbols	Rated Value			Units	Remarks
		Min.	Typ.	Max.		
Input cycle	$t_c$	—	62.5	—	ns	16 MHz
Clock pulse width	$t_{WH}, t_{WL}$	10	—	—	ns	

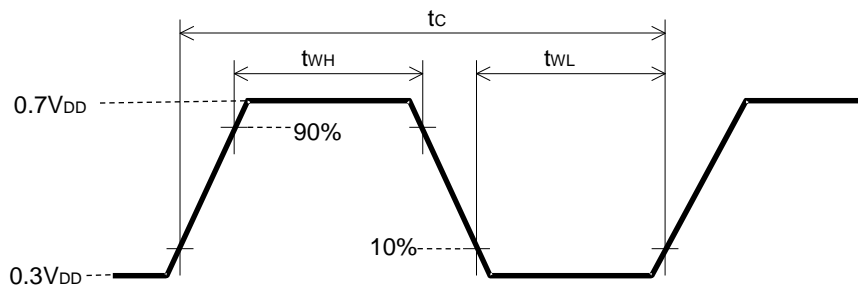

5.3.4 Clock input circuit

when ceramic oscillator is used.

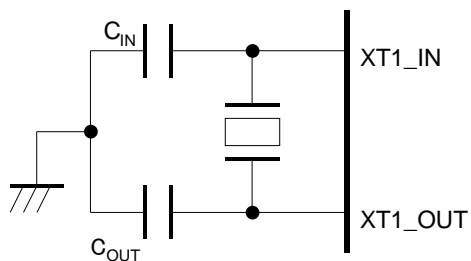

External clock input circuit

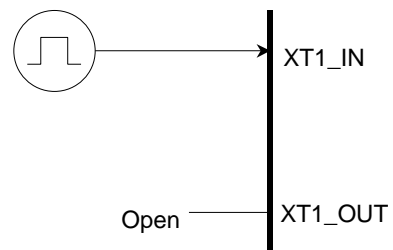

**6. Packaging specification**

**6.1 Outline**

TSC-52/IC is packaged with an unit of 500 pcs. and if the quantity is 500 pcs. or multiple number of 500 pcs., the products will be put into aluminum bags with humidity-proof function with a unit of 500 pcs. which is defined as basic packaging. If the quantity is less than 500 pcs. or not multiple number of 500 pcs., fraction number of the products to 500 pcs. will be into non-humidity-proof package called small-quantity-packaging In the event of small-quantity-packaging, the product must be baked before use at client in accordance with the clause 7.2 “Baking”, and then chip-mounted.

**6.2 Notes on storage and handling**

- (1) Handle with care since a big impact given by throwing down and/or falling may lead to damage of the products such as broke of packing materials, broke of IC packages, and bending of leads.
- (2) Cardboard box may deform sue to deterioration in strength depending on humidity in storage place, multiple stack of boxes and/or storage term. Storage is preferable to be done in normal temperature and humidity environment of 5 to 30°C and 40 to 60 %RH. Also stick to first-in-first-out.
- (3) Care must be taken against breakdown due to ESD after the product being taken out of the box.

**6.3 Basic packaging**

Type of packaging is called “Humidity-proof packaging with aluminum bag”

Quantity in container		
quantity per tray	number of tray	Quantity in container
250 pcs.	2-tray + 1-tray as lid	500 pcs.

Illustration of packaging

- 1) Trays are stacked up and bundled up with nylon tie.

- 2) The trays are put into an aluminum bag and then vacuum packed.

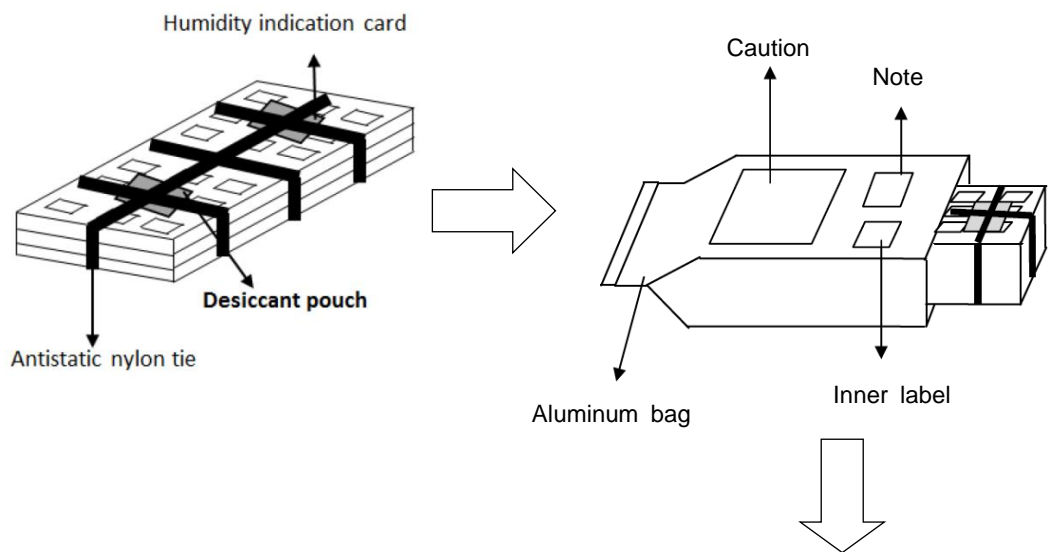

4) Put it into the Packaging box.

3) The aluminum bag is wrapped up with bubbled sheet.

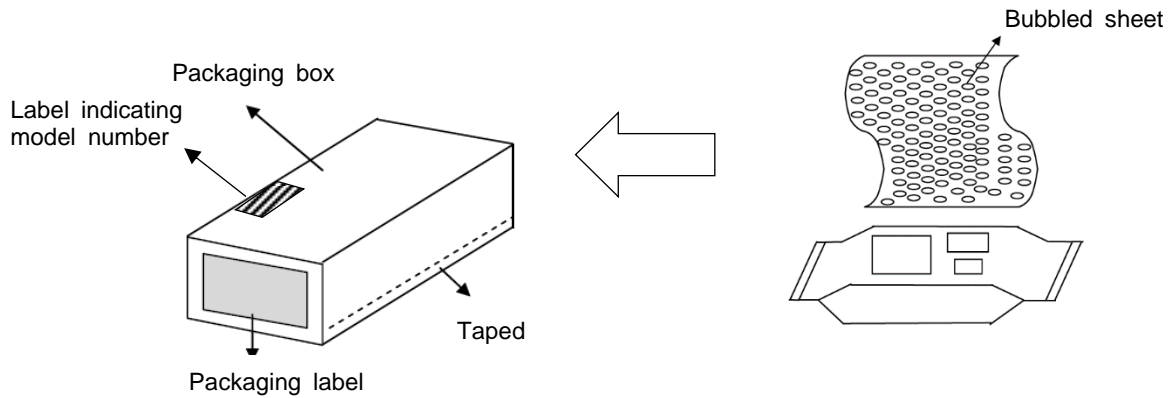

**6.4 Small-quantity-packaging**

• Type of packaging is called “General packaging”.

• Quantity in container

Quantity per tray	Number of tray	Quantity in container
250 pcs.	1 or 2-tray + 1-tray as lid	1~499

• Illustration of packaging

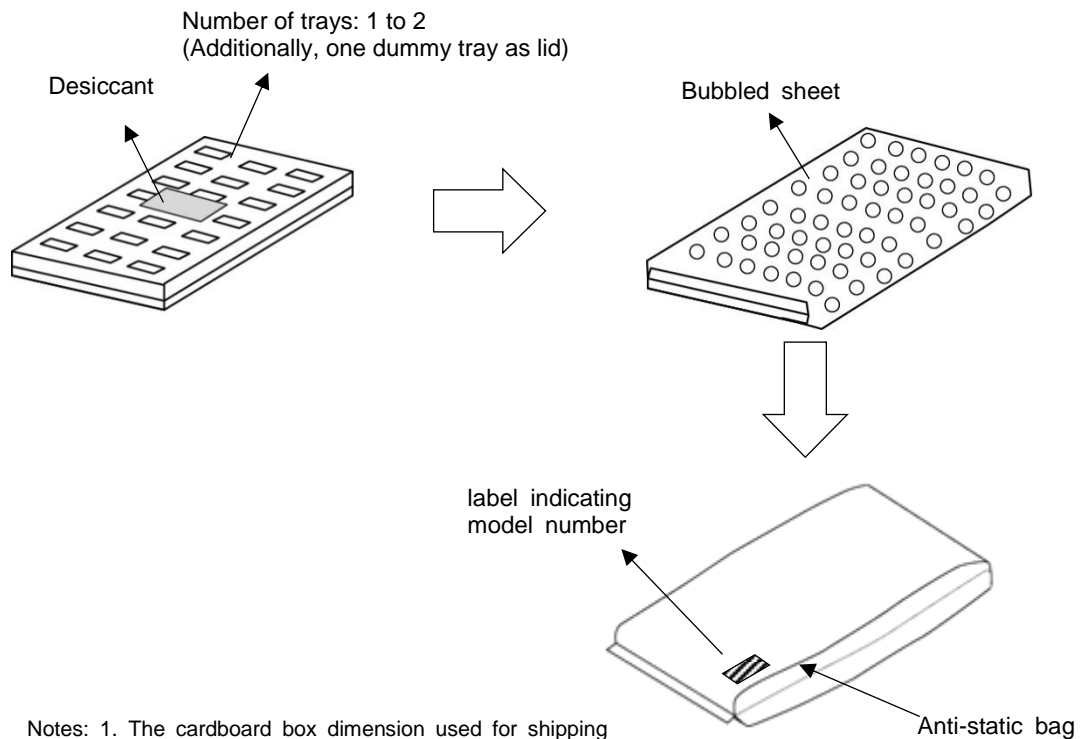

Notes: 1. The cardboard box dimension used for shipping is not particularly specified and may vary.  
 2. The packaging shown above is an example and may slightly differ in cases.

**6.5 Tray specification**

The tray is heat-resistant and can be durable 24 hours under 125°C. However, it may receive warping when heated and/or cooled. In the event of baking, in order to minimize warping, heating and/or cooling must be done with the tray placed on flat plate.

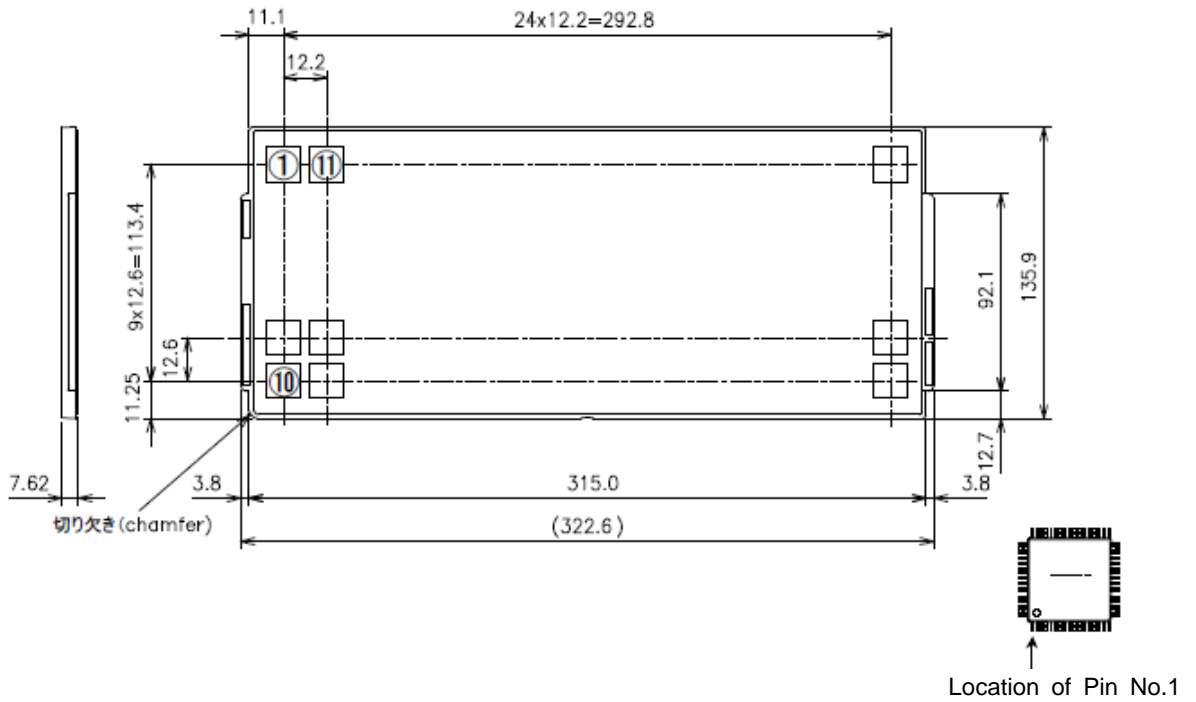

**6.6 Model name indication specification**

DMC P/N(model number) : TSC-52/IC as DMC model number

QTY : quantity

DAC : DMC administration number



## 7. Storage specification

### 7.1 Storage condition

In the case the products are stored until use, the following conditions are recommended.

- (1) Before humidity-proof packaging with aluminum bag is not opened, store the products in the following conditions.

temperature, humidity : <40°C, <90%RH

term : ≤12 months

- (2) After humidity-proof packaging is opened, implement either of the followings.

When reflow soldering or other treatment with high temperature is implemented, the below must be followed.

- a) The products must be chip-mounted within 168 hours after opening the packaging with them placed in the environment of 30°C and 60%RH.
- b) The product must be stored with the environment of less than 10%RH.

### 7.2 Baking

If the products are applicable to either of the following two conditions, before chip mounting, baking is necessary with the conditions as shown below to expel moisture the products have absorbed. In addition, the tray used for humidity-proof packaging can be put into constant temperature chamber, but in that case, the tray must be placed on the stable flat plate to avoid deformation when it is put into the chamber and then cooled down afterwards.

- 1) When humidity indicator shows >10%RH seen at the environment of 23±5 °C.
- 2) When either of a) and b) written in the clause 7.1 (2) are not observed.

•Baking method

Temperature: 125±5 °C

Time: 24 hours



**8. Mounting specification**

**Temperature conditions for mounting**

If the products are chip mounted using reflow soldering method, the reflow soldering conditions must be carefully decided taking the temperature profile shown below into consideration since soldering quality is influenced by solder melting temperature and/or solder paste material. Wave-soldering is not recommended.

(1) Reflow method (Infrared reflow, Air reflow)

Temperature: The recommended reflow flow is shown below.

Reflow number: Up to three(3) times

**Pb Free & Halogen Free IR-Profile**

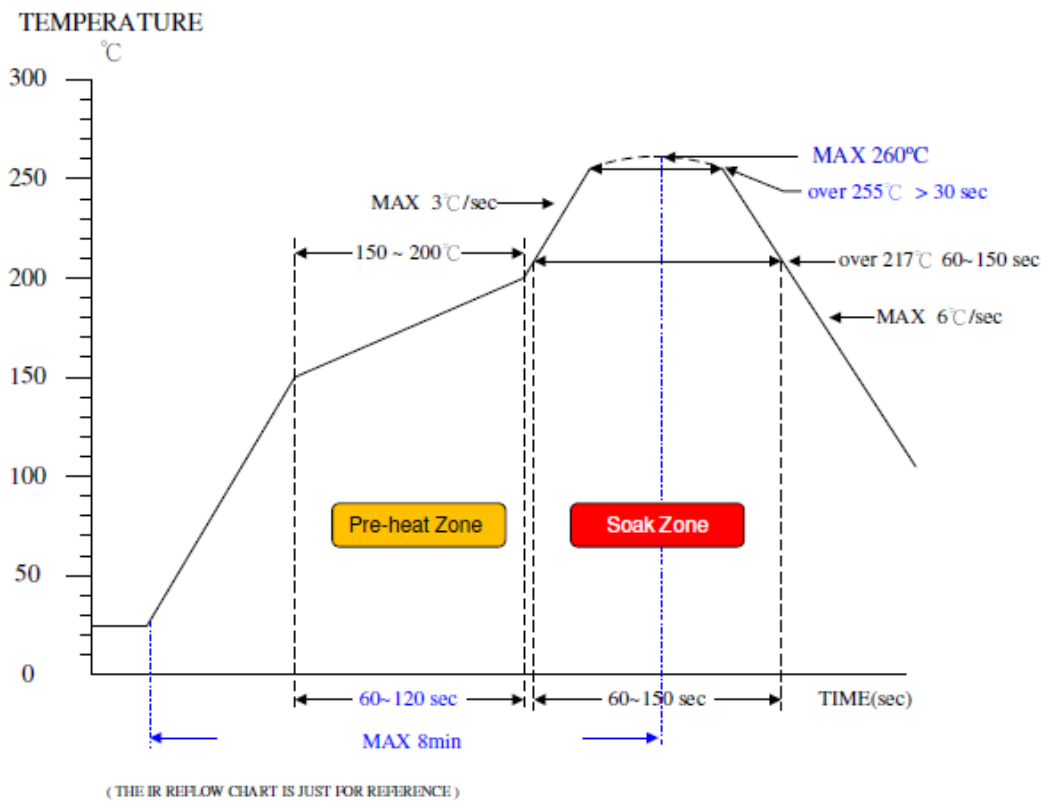

Figure. Temperature profile for reflow soldering

(2) Soldering iron (Manual soldering)

Use soldering iron for semiconductor use and do soldering observing the conditions below.

Soldering tip temperature : 355±5 °C

Soldering time : within 5 sec. per terminal

## **9. Terminal specification**

Terminal material: Cu alloy

Lead plating: Tin(Sn)

Plating thickness: 8 to 20 um

## **10. Warranty**

### **10.1 Warranty period**

The warranty period is limited to 1 year from the date of delivery. The warranty for the initial defects such as appearance is limited to within one(1) month after delivery at client's site.

If the products are found failure under proper use, such products are replaced with the new products if such defects are determined to be supplier's faulty workmanship.

The replacement can be fulfilled in the next production lot.

### **10.2 Warranty scope**

The warranty only covers the product itself and does not cover any secondly damage caused by using the concerned products. Also onsite repair or replacement shall not be supported.

We will sincerely respond to delivery problems and/or product defects, but damage for client's production lines shall not be guaranteed.

### **10.3 Warranty Exceptions**

Following conditions are not covered with the warranty and subject to charge.

Any malfunctions and damages during transportation and transfer by clients.

Any malfunctions and damages caused by a natural disaster or force majeure.

Any malfunctions and damages caused by static electricity.

Any malfunctions and damages caused by failure of the associated equipment in which the products are embedded.

In the case the product is remodeled, disassembled or repaired by clients.

In the case the product is uninstalled after glued onto equipment.

Any malfunctions and damages caused by an improper usage and handling against the clauses in this specifications.

## **11. Notes on use**

### **11.1 Overall handlings**

When using the product, do not place it close to, or make it contact with, conductive materials such as metal.

Do not touch the metal part in the product directly with your hands since it may damage the product by static electricity. If you contact, or may contact, it directly with your hand, prepare in advance the measure against static electricity.

To store the product, use an appropriate packing box and keep the storage temperature range with no overload on it.

In using the product or storing it, avoid the following conditions:

- 1) Conditions where water is, or may be, attached to the product.
- 2) Conditions where condensation takes place, or may take place.
- 3) In the ambience of organic solvent or acidity, or where the product contacts them.

Do not alter or disassemble the product.

## 11.2 Others

This specification may be changed for improvement without prior notice.

No liabilities are taken by us for any damage caused by use of this product.

This product intends to be used for the standard applications (e.g. office equipment and OA devices, industrial use, communication devices, household equipment). Avoid its use where failure or malfunction directly may affect the human body or special applications where extremely high reliability is required (e.g. airline and space industries, nuclear controls, medical use for life-sustaining).

Semiconductor device may fail with a certain possibility. Keep safety design in your mind so that possible failure in this product shall not cause physical accidents such as injury and death, fire and other social damages.

## 12.Revision history

TSC-52/IC

Ver.1.0 (October 1, 2020)

First edition was issued.

Ver.2.0 (June 11, 2021)

5.3.1 Power on Reset: () was deleted. Added "Temperature" to the table. Added explanation in the remarks column.

Outline Dimensions for IC package: Description error is corrected in the symbol. (H -> D)

Recommended Circuit: Added 1% as the accuracy of the resistor. (R30,R31,R34,R37,R38,R41)

TSC-52 /IC Product Specification

©2021 DMC Co., Ltd.

This document is allowed to redistribute but no alteration, part or all, is prohibited.

**DMC Co., Ltd.**

<http://www.dmccoltd.com/english/>

11F Takanawa Sengakuji Ekimae Bldg., 2-18-10 Takanawa, Minato-ku, Tokyo 108-0074, Japan

Phone: +81-3-6721-6731 (Japanese), 6736 (English) Fax: +81-3-6721-6732

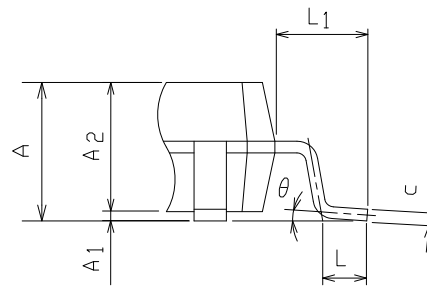
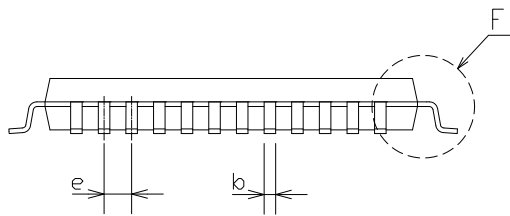
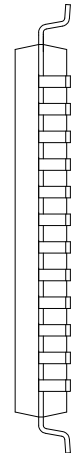
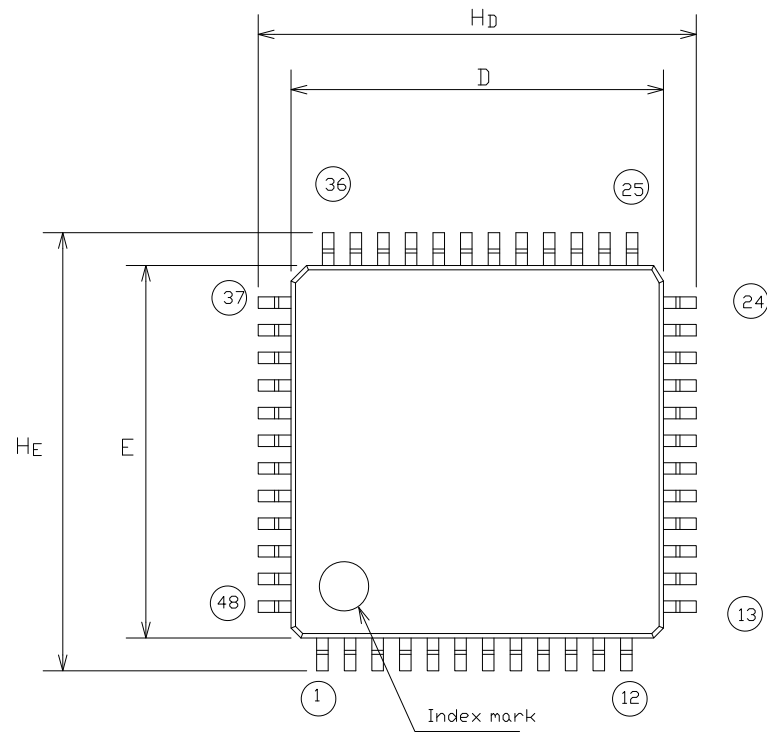

Detail F

Symbol	Dimension in Millimeters		
	Min	Nom	Max
A	-	-	-
A <sub>1</sub>	0.05	0.10	0.15
A <sub>2</sub>	1.35	1.40	1.45
b	0.15	0.20	0.25
c	0.10	0.15	0.20
D	6.90	7.00	7.10
E	6.90	7.00	7.10
e	0.35	0.50	0.65
H <sub>D</sub>	8.90	9.00	9.10
H <sub>E</sub>	8.90	9.00	9.10
L	0.45	0.60	0.75
L <sub>1</sub>	-	1.00	-
Y	-	-	0.10
$\theta$	0°	-	7°

Date	P/N
June 4, 2021	TSC-52/IC
Name	
Dimensional Drawing Rev.1.1	
DMC Co., Ltd.	

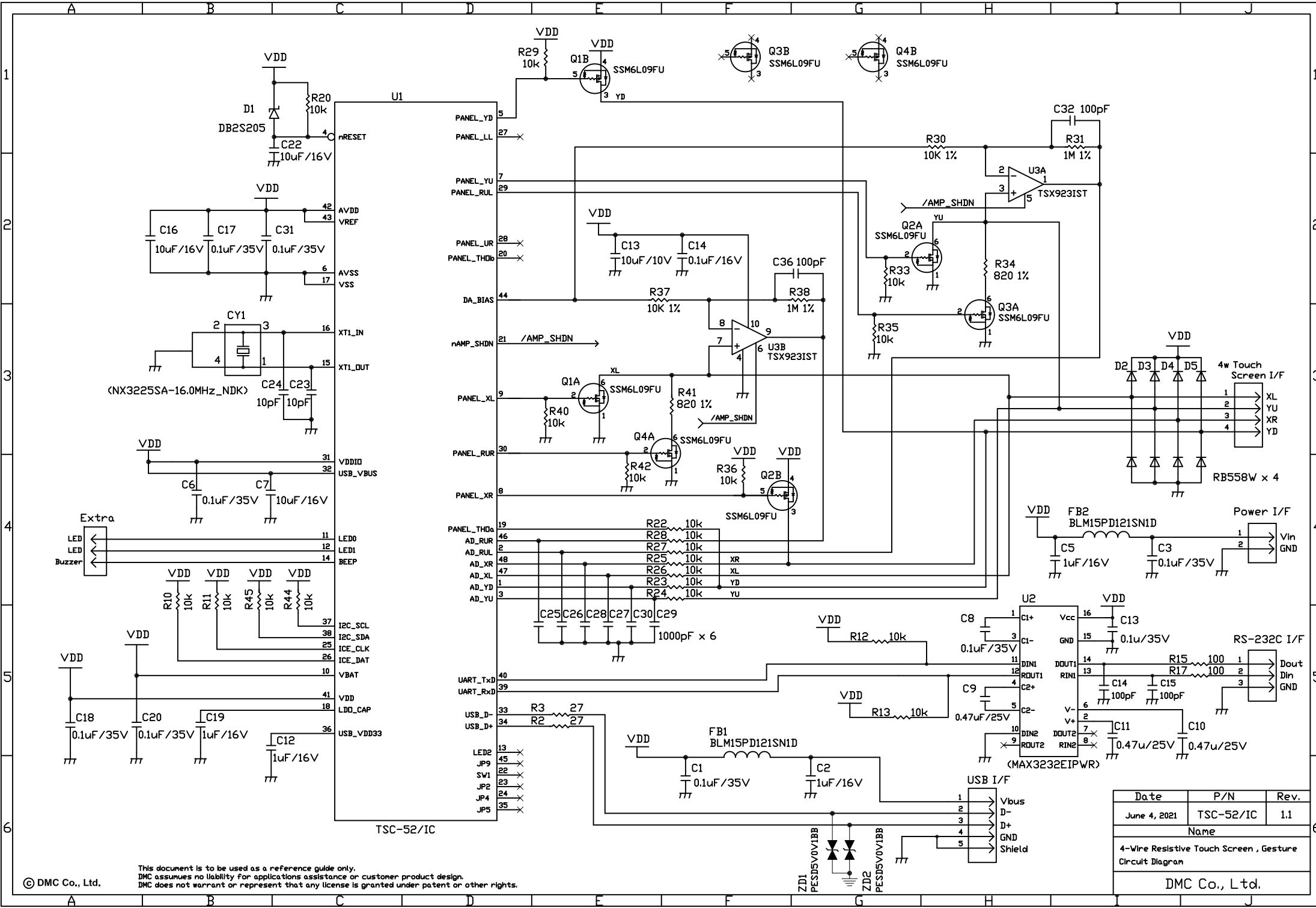

This document is to be used as a reference guide only.  
 DMC assumes no liability for applications assistance or customer product design.  
 DMC does not warrant or represent that any license is granted under patent or other rights.

Date	P/N	Rev.
June 4, 2021	TSC-52/IC	1.1
Name		
4-Wire Resistive Touch Screen , Gesture Circuit Diagram		
DMC Co., Ltd.		